

Operation Manual

COLOR INKJET PRINTER

TXF150-75

TXF300-75

OPERATION MANUAL

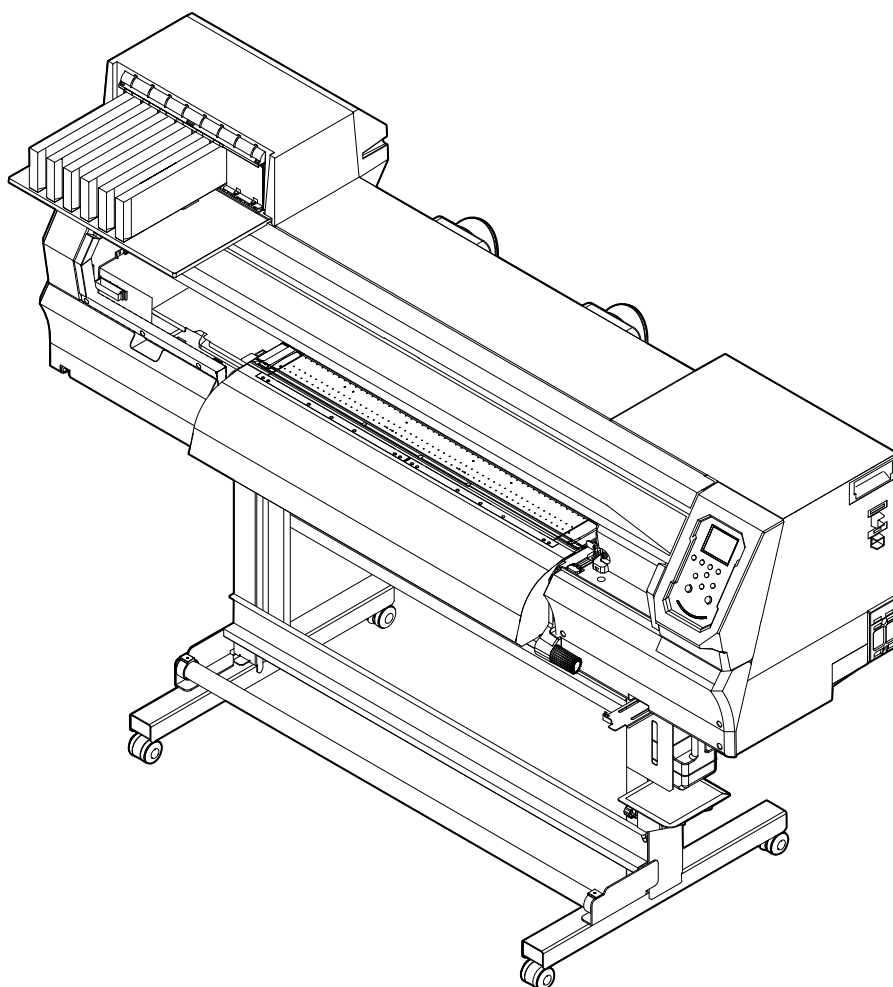

Download the latest version of the operation manual from our website.

MIMAKI ENGINEERING CO., LTD.

URL: <https://mimaki.com/>

D203671-21

Original instructions

Contents

Introduction	v
Caution	v
Requests	v
FCC statement (USA)	v
TV and radio interference	v
Compatible ink	v
Safety Precautions	vi
Symbols	vi
Working Environment	ix
Place of installation	ix
Temperature of working environment	ix
Warning Labels	x
Chapter 1 Before Use	
Part Names and Functions	1-4
Front	1-4
Rear/side	1-5
Operating panel	1-6
Media sensor	1-8
Carriage	1-8
Cutter blade and cutting slot	1-8
Capping station	1-8
Pinch rollers and grit rollers	1-9
Connecting Cables	1-9
Connecting a USB 2.0 interface cable	1-9
Inserting Ink Cartridges	1-11
Precautions on handling ink cartridges	1-11
Inserting ink cartridges	1-11
When Ink Level Low or Ink Near End is Displayed	1-13
When Replace Inkpack (Ink End) is Displayed	1-13
Ink cartridge lamps	1-14
Machine restrictions	1-14
Replacing Ink	1-14
Menu Mode	1-17
Chapter 2 Basic Operations	
Workflow	2-4
Turning the Power On/Off	2-5
Turning the power on	2-5
Turning the power off	2-5
Loading Media	2-6
Adjusting head height	2-6
Loading roll media	2-7
Changing the printing origin	2-9
Preparing the Heater	2-10
Changing heater temperature settings	2-10
Test Printing	2-10
Test printing	2-11
Head Cleaning	2-11
About head cleaning	2-11
Performing head cleaning based on test printing results	2-11
Feed Correction Settings	2-12
Feed correction	2-12

If the Positions of Dots Shift	2-13
Printing Data	2-13
Starting printing	2-13
Pausing printing	2-14
Clearing received data (Data Clear)	2-14
Cutting media	2-14
Chapter 3 Settings	
Setup Menu	3-2
Setup menu table	3-2
Registering optimal print conditions to match usage	3-3
Feed correction	3-3
Dot position correction	3-3
Heater	3-4
Logical seek	3-4
Drying time	3-5
Margin (left/right)	3-5
Vacuum fan	3-5
Feed speed	3-5
MAPS	3-6
Auto cleaning	3-6
Interval wiping	3-6
Machine Setup Menu	3-7
Machine setup menu table	3-7
Setting auto power-off	3-9
Setting remaining media display	3-9
Setting the language	3-9
Setting the time	3-9
Setting units (temperature/length)	3-9
Registering and Correcting a Ink Cartridge	3-9
Setting the key buzzer	3-10
Setting view feed	3-10
Setting space feed mode	3-11
Setting the network	3-11
Setting the event mail function	3-12
Initializing settings	3-15
Nozzle Check Menu	3-16
Nozzle check menu table	3-16
Nozzle check flow during printing	3-17
Printing operations when nozzle clogging is determined or errors occur	3-17
Setting nozzle checking during printing	3-18
Setting auto nozzle recovery	3-18
Setting judgment conditions	3-18
Information Menu	3-19
Information menu table	3-19
Displaying information	3-19
Chapter 4 Maintenance	
Maintenance Precautions	4-2
Performing Maintenance	4-3
Maintenance items and timing	4-3
Tools required for maintenance	4-3
Routine Maintenance	4-4
Ink maintenance	4-4

Cleaning the wiper and cap	4-4
Cleaning the wiper cleaner	4-5
Cleaning the wiper ink guard	4-5
Cleaning under the carriage	4-5
NCU Cleaning	4-7
Cleaning the waste ink draining channel	4-7
Cleaning head nozzles	4-8
Preparing the machine if it will not be used over extended periods	4-9
Cleaning media sensors	4-10
Cleaning media holders	4-10
Cleaning the platen	4-10
Cleaning exterior surfaces	4-11
Cleaning jam sensors	4-11
Maintenance Functions	4-12
Nozzle recovery function	4-13
Auto Maintenance Functions	4-14
Filling with ink	4-15
Replacing Consumables	4-16
Replacing wipers	4-16
Replacing exhaust box filters	4-16
Replacing the CP pad set	4-17
Replacing pinch rollers	4-17
Replacing fan filters	4-18
Replacing cutter blades	4-18
Waste Ink Tank	4-19
In case of messages to check waste ink	4-19
Examples of Printing Issues	4-21
Recovering from nozzle ejection failure	4-22
Recovering from frequent nozzle dropout and nozzle ejection failures of white	4-22
Chapter 5 Troubleshooting	
Troubleshooting	5-2
Power does not turn on	5-2
Printing is not possible	5-2
Media jams or is dirty	5-2
Heater temperature does not rise to the set level	5-2
Image quality is poor	5-3
Nozzles are clogged	5-3
Ink cartridge warning appears	5-3
Ink leakage occurs	5-3
Warning/Error Messages	5-4
Warning messages	5-4
Error messages	5-6
Chapter 6 Appendix	
Specifications	6-2
Main unit specifications	6-2
Ink specifications	6-4
Order for Loading Ink Cartridges	6-5
LICENSE Library	6-6



Introduction

Thank you for purchasing the TxF150-75 / TxF300-75 color inkjet printer.

The TxF150-75 / TxF300-75 (hereafter, "the machine") is a color inkjet printer supporting high image quality that prints with Pigment Heat Transfer Ink on media 810mm wide.

Unauthorized reproduction of any portion of this document is strictly prohibited.

© Mimaki Engineering Co., Ltd.

All Rights Reserved. Copyright

Caution

Mimaki Engineering Co., Ltd. is in no way liable for any damages whatsoever (including but not limited to lost profit, indirect damage, special damage, or other monetary damage) arising from using or inability to use the machine, except as provided in Mimaki warranty provisions.

This applies even if Mimaki has been informed of the possibility of such damages.

For example, we cannot be held liable for any loss of media or other materials from using the machine, nor are we liable for any indirect loss caused by printed materials.

Please note that we are not liable for any financial damage or lost profits resulting from the use of the machine, or for any claims from third parties.

Requests

- This manual describes the operations and maintenance of the machine.
- Illustrations in the manual may be different from the appearance of some models.
- Read this manual carefully and make sure you understand it before use.
- Although every effort has been made to ensure the accuracy of the information in this manual, if you find any issues, contact your dealer, our service office, or our call center.
- This manual is subject to change without notice for improvement.
- You can also download the latest manual from our website.

FCC statement (USA)

The machine has been tested and found to comply with the limits for a Class A digital device, pursuant to Part 15 of the FCC Rules. These limits are designed to provide reasonable protection against harmful interference when the machine is operated in a commercial environment.

The machine generates, uses, and can radiate radio frequency energy and, if not installed and used in accordance with the operation manual, may cause harmful interference to radio communications.

VCCI-A

TV and radio interference

In use, the machine emits high-frequency electromagnetic radiation. If installed or used incorrectly, this may result in TV or radio interference. Accordingly, there is no assurance that the machine will not affect special radio or TV equipment.

If you believe the machine is interfering with radio/TV reception, turn it off to confirm. If interference is alleviated when the machine is off, the machine is likely to be causing the interference.

Try any of the following solutions or combinations of solutions:

- Change the orientation of the TV or radio antenna to find a position where interference does not occur.
- Place TVs or radios away from the machine.
- Plug TVs or radios into outlets on a different power supply path than the machine.

Compatible ink









The ink used with the machine is thermal transfer pigment ink.

Safety Precautions

Symbols

In this manual, symbols indicate and explain precautions. The indicated symbol varies depending on the nature of the precaution. Make sure you understand the meaning of each symbol and use the machine safely and correctly.

Examples of symbols

Meaning	
	Failure to observe the instructions given with this symbol may result in death or serious injuries to personnel. Be sure to read the precaution carefully and use the machine correctly.
	Failure to observe the instructions given with this symbol may result in injury to personnel or damage to property.
	Important notes regarding use of the machine are given with this symbol. Use as reference information.
	Useful information is given with this symbol. Use as reference information.
	Indicates the corresponding page for related information.
	△ Indicates a precaution requiring attention (including cases of danger or warnings). Specific precautions are shown in the figure.
	⊘ Indicates a prohibited action. Specifically prohibited actions are shown in the figure.
	● Indicates an action that must be taken or instructions that must be followed. Specific instructions are shown in the figure.

Warnings and precautions in use

⚠ WARNING



- The set of power cables provided with the machine is for use only with the machine and cannot be used with other electrical devices. Do not use any power cables other than the ones provided with the machine. Failure to observe these instructions may result in fire or electric shock.
- Do not attempt to modify the cable, and avoid damaging or breaking it. Placing heavy objects on, heating, or pulling the cable may damage it, which may result in fire or electric shock.
- Avoid use in humid places. Additionally, do not pour water on the machine. Failure to observe these instructions may result in fire, electric shock, or failure.
- Use of the machine under an abnormal condition, as when it is emitting smoke or fumes, may result in fire or electric shock. Turn off the power switch immediately, and then be sure to unplug the machine from the outlet. Once you have confirmed that smoke is no longer being emitted, request repair from your dealer or service office. Never attempt to repair the machine yourself. Doing so is hazardous.
- Never disassemble or modify the machine or ink cartridges. Failure to observe these instructions may result in electric shock or failure.
- Do not use extension cords. Failure to observe these instructions may result in fire or electric shock.
- Keep foreign objects such as pieces of metal away from the power plug prongs. Failure to observe these instructions may result in fire or electric shock.
- Do not overload electrical outlets by using too many pieces of equipment. Failure to observe these instructions may result in fire or electric shock.
- If the power cable is damaged or the core wire is exposed or broken, ask your service representative to replace it. Using it as is may result in fire or electric shock.
- Do not handle the power plug with wet hands. Failure to observe these instructions may result in electric shock.
- Always hold the power cable by the plug when unplugging the machine. Do not unplug by holding the power cable. Failure to observe these instructions may damage the cable or result in fire or electric shock.
- Do not use a voltage other than the indicated voltage. Failure to observe these instructions may result in fire or electric shock.
- Do not use a power frequency other than the indicated frequency. Failure to observe these instructions may result in fire or electric shock.
- If metal, water, liquid, or other foreign objects enter the machine, turn it off immediately. After that, be sure to unplug the machine and contact your service representative. Using it as is may result in fire or electric shock.
- If ink leaks, turn off the main power switch, unplug the machine, and contact your dealer, service office, or call center.
- Keep the heater on the media transport surface free of dust and debris. Failure to observe these instructions may result in sparks or fires.
- Keep children away from this machine.



- Do not use a flammable spray or solvent inside or around the machine. Failure to observe these instructions may result in fire or electric shock from ignition.
- Do not place vases, pot plants, cups, cosmetics, containers of chemicals or water, or small metal objects on top of the machine. Liquid or foreign objects may get inside the machine, leading to fire or electric shock.

Precautions in use

CAUTION**Handling of the power cable**

- Plug into a polarized electrical outlet.
- Always plug the power cable into an outlet near the machine, and make sure the power cable can be easily unplugged.
- Regularly (at least once a year) unplug the cable and remove any dust on or near the power plug. Failure to remove dust may result in fire.
- Do not use a voltage other than the indicated voltage.
- Before plugging in the machine, check the outlet supply voltage and circuit breaker capacity. Plug each cable into a power source with an independent breaker. If you plug more than one power cable into outlets that share the same circuit breaker, it may trip the breaker.

Power supply

- Leave the breaker in the ON position.
- Do not turn off the main power switch on the side of the machine.

Notes on maintenance

- Pay close attention to ventilation and be sure to wear safety glasses, gloves, and a mask when handling ink, maintenance liquid, waste ink, or other solutions used with the machine. Leaking ink may adhere to the skin or get into the eyes or mouth.
- Gloves are consumables. After you have worn out the included gloves, purchase and use commercially available gloves.

Moving part precautions

- Keep fingers and other body parts away from hazardous moving parts.
- Do not touch the grit roller when it is rolling. Failure to observe these instructions may result in finger injury such as torn skin or fingernails.
- Keep your head and hands away from moving parts during cutting operation. Failure to observe these instructions may result in injury such as your hair becoming caught in the machine.
- Wear suitable clothes. (Do not wear loose-fitting clothes or accessories.) Keep long hair bound.

CAUTION**Ink**

- Ink cartridges are labeled with precautions about the ink. Thoroughly read them and make sure you understand the contents.
- Before using ink and maintenance liquid, be sure to read the Safety Data Sheet (SDS) and instruction manual for ink. <https://mimaki.com/supply/sds/>
- Keep ink away from open flame. Also, be sure that the room is well ventilated when using or handling ink.
- Immediately wipe off any ink, maintenance liquid, waste ink, or other liquid used with the machine that comes into contact with your skin using a cloth. Wash with soap and rinse with plenty of water. Failure to observe these instructions may result in skin inflammation. If your skin becomes irritated or painful, seek medical attention immediately.
- If ink, maintenance liquid, waste ink, or any other liquid used with the machine comes into contact with your eyes, rinse immediately with plenty of clean water. Rinse for at least 15 minutes. If you wear contact lenses and they can be easily removed, remove after rinsing for at least 15 minutes with clean water. Rinse thoroughly, including the undersides of your eyelids. Failure to observe these instructions may result in blindness or impaired vision. If your eyes become irritated or painful, seek medical attention immediately.
- If ink, maintenance liquid, waste ink, or any other liquid used with the machine enters your mouth or is swallowed, gargle with water immediately. Do not induce vomiting. Seek medical attention promptly. Inducing vomiting may cause liquid to enter the airway.
- If a large amount of vapor is inhaled, move to a well-ventilated area, keep warm, and rest in a posture that allows easy breathing. If the condition does not improve, seek medical attention promptly.

Media

- At least two people must work together to load roll media. Working alone may cause back injury from the weight of rolls.
- When replacing media, be careful not to pinch your fingers or injure yourself.
- The machine is equipped with an internal media cutter. When replacing or loading media or clearing media jams, do not touch areas other than those specified in this manual. Failure to observe these instructions may result in injury.

Cutter

- Do not touch the cutter blade, which is very sharp.
- Store the cutter blade out of the reach of children. Dispose of used cutter blades according to local regulations.

Heater

- Do not pour liquid on the media transport surface. Failure to observe these instructions may result in heater failure or sparks.
- Do not touch the media transport surface with bare hands while the heater is hot. Failure to observe these instructions may result in burns.

Machine handling precautions

CAUTION

- Do not use in unventilated or poorly ventilated rooms.
- Provide sufficient ventilation when the machine is in use.
- For assistance with cleaning the inside the machine, contact your service representative. Failure to clean the machine over extended periods when dust has accumulated inside may result in fire or failure.

Precautions and notes**WARNING****Handling of ink cartridges**

- The machine's safety rating is based on using ink recommended by Mimaki. To ensure safe operation, use ink recommended by Mimaki.
- If the ink cartridges are brought from a cold place to a warm place, leave them at room temperature for at least three hours before use.
- Open the ink cartridges just before installation. If they are left open over an extended period, it may not be possible to print normally.
- Store ink cartridges in a cool, dark place.
- Keep ink cartridges and waste ink tanks out of the reach of children.
- Once an ink cartridge is opened, use up the ink within one month. Printing quality declines after cartridges have been open over an extended period.
- Please hand over unused ink cartridges, ink packs, and waste ink to your dealer or service representative. If you dispose of them by yourself, comply with requirements of your industrial waste disposer and local regulations.
- Do not hit ink cartridges or shake them roughly. This may cause ink to leak from the cartridge.
- Do not attempt to refill ink packs or ink cartridges. Mimaki is not responsible for any problems caused by using refilled ink.
- Do not touch and avoid soiling ink cartridge PCB contacts. This may result in PCB failure.

Clamp lever

- Do not raise the lever during printing. Raising the lever will stop printing.

Components requiring periodic replacement

- Some parts of the machine require regular replacement. For long-term use of the machine, be sure to apply for an annual maintenance contract.

Machine disposal

- Contact your dealer or service representative for assistance when disposing of the machine. If you will dispose it by yourself, request assistance from an industrial waste disposer.

Notes on maintenance

- Use in a room with as little dust as possible.
- Dust may also cause sudden dripping of ink from the heads onto the media during printing. In this case, clean around the heads.
- Keep the capping station and wiper clean by wiping them to remove dust and paper dust.







WARNING

- Store media in a bag. Wiping off dust accumulated on media will adversely affect the media due to static electricity.
- When leaving the workshop after working hours, do not leave any media on the roll hanger. Dust will adhere to the media.

Handling of media

- Use recommended media. Use the media recommended by Mimaki to ensure reliable, high-quality printing.
- Be aware of media expansion and contraction. Do not use media that has just been opened. The media may expand or contract depending on the room temperature and humidity. Open the package and allow it to adjust to the place of use for at least 30 minutes before loading it in the machine.
- Do not use curled media. Not only does this cause media jamming, it also affects printing quality. Straighten any media that is significantly curled before use. When rolling up regular-sized coated media for storage, make sure the coated side is facing outward.
- Be aware of any dust along the edges of media. With some roll media, dust inside the package may collect at the ends of the roll. Using dusty media may cause nozzle clogging, dripping, or other issues that may reduce printing quality. Remove any dust at the ends of rolls before loading them.
- Set the heater temperature to suit media characteristics.
- Set the temperature of the pre-heater, print heater, and post-heater to suit the type and characteristics of the media. Another method is to specify automatic temperature setting from the operating panel by specifying a profile from a dedicated RIP. For instructions, refer to your RIP instruction manual.
- Do not leave media loaded over extended periods with the heater on.
- With some types of media, the ink-receiving layer may melt under high temperature and humidity. Be careful about where media is stored.
- With some types of media, the ink-receiving layer may change if the media is left exposed to air, causing image defects such as blurred colors and bleeding.

Installation precautions

⚠ CAUTION	
Places exposed to direct sunlight	Places with uneven surfaces
	
Places where vibration is generated	Places directly exposed to air conditioning
	
Places subject to significant changes in temperature or humidity	Places where open flames are present
<p> • Use the machine under the following environmental conditions:</p> <ul style="list-style-type: none"> • Operating environment: 20–30°C (68–86°F) 35–65% RH 	

Working Environment

Place of installation

Before installing the machine, ensure that the required amount of space is available in the place under consideration. The place of installation must have enough space for the machine as well as printing tasks.

Model	Width	Depth	Height	Total weight
TxF150-75	1965 mm	700 mm	1392 mm	126 kg
TxF300-75	1965 mm	700 mm	1392 mm	126 kg

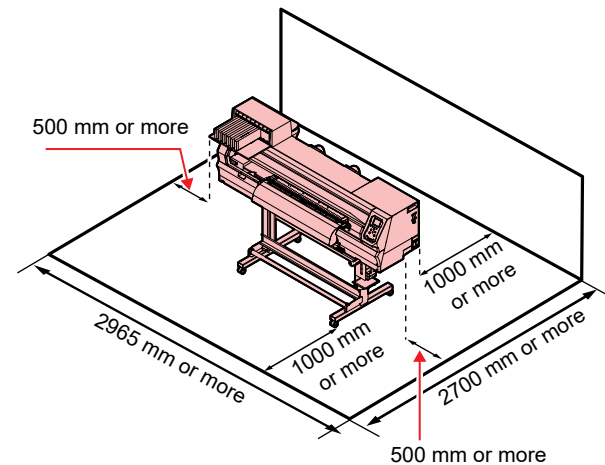

Temperature of working environment

To ensure reliable printing, use the machine in an environment of 20–30°C.

Warning Labels

Warning labels have been applied to the machine as shown. Make sure you fully understand the details indicated on the various warning labels.

If a warning label is illegible due to soiling or has come off, purchase a new one from a dealer or our sales office.

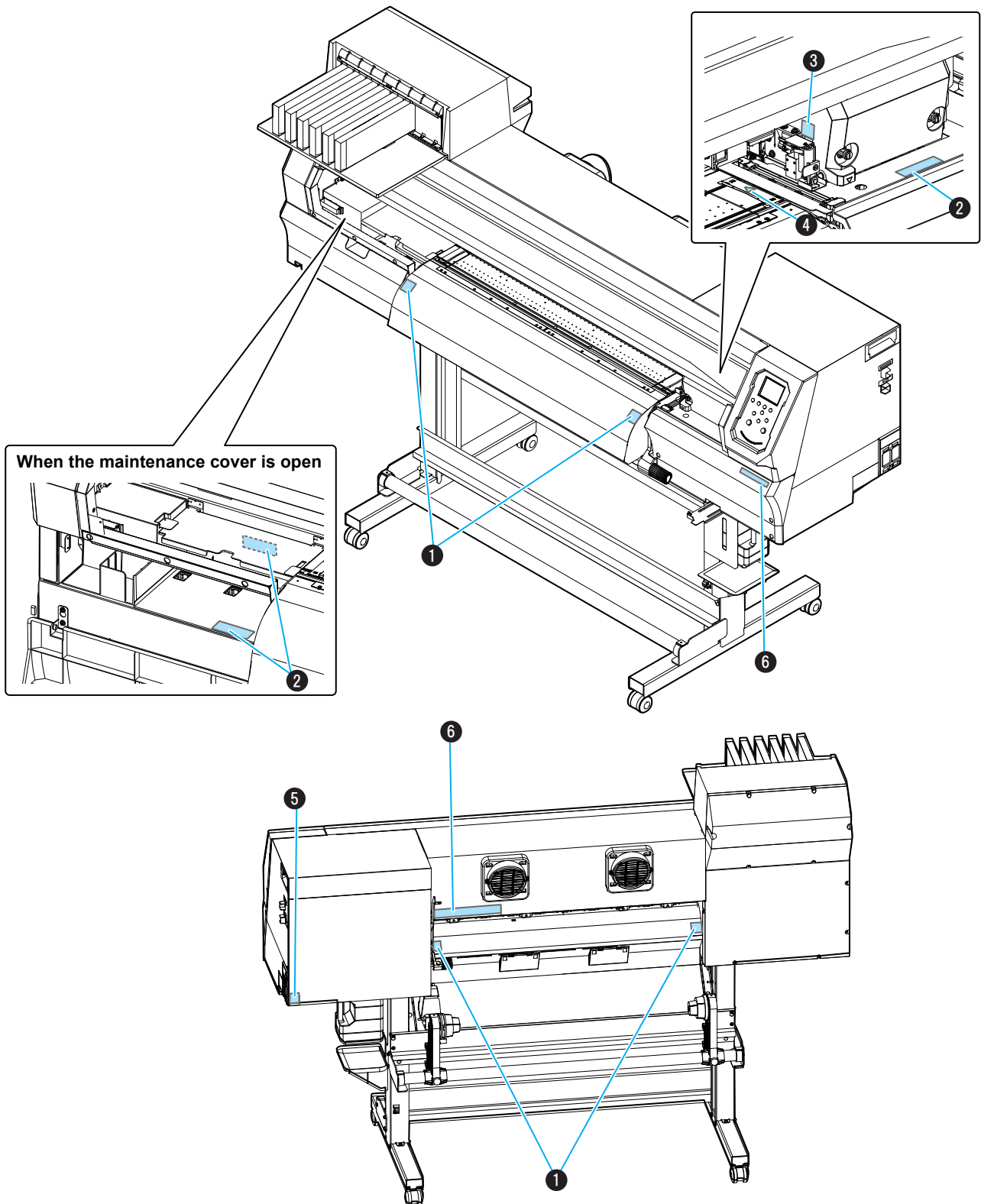





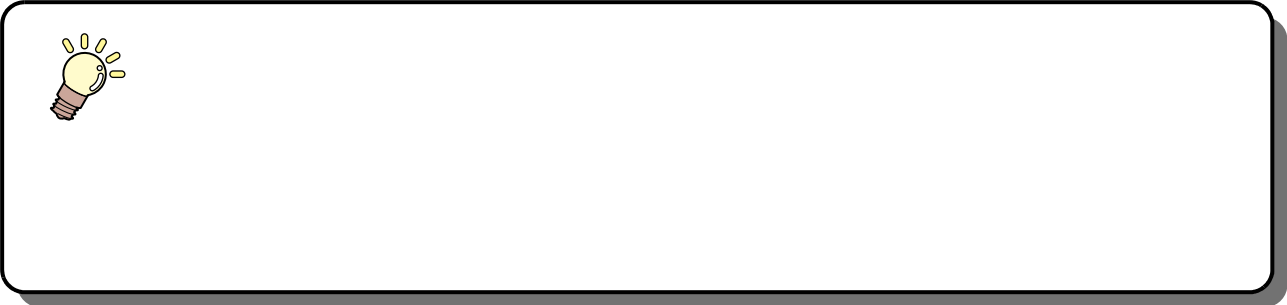

Illustration: TxF150-75

No.	Order code	Label
1	M903239	
2	M903330	
3	M903405	
4	M906144	
5	M907935	
6	M905811	



Part Names and Functions	1-4	When Ink Level Low or Ink Near End is Displayed	1-13
Front	1-4	When Replace Inkpack (Ink End) is Displayed	1-13
Rear/side	1-5	Ink cartridge lamps	1-14
Operating panel	1-6	Machine restrictions	1-14
Media sensor	1-8	Replacing Ink	1-14
Carriage	1-8	Menu Mode	1-17
Cutter blade and cutting slot	1-8		
Capping station	1-8		
Pinch rollers and grit rollers	1-9		
Connecting Cables	1-9		
Connecting a USB 2.0 interface cable	1-9		
Inserting Ink Cartridges	1-11		
Precautions on handling ink cartridges	1-11		
Inserting ink cartridges	1-11		

Chapter 1 Before Use



About this chapter

This chapter describes information to know before use, such as part names and installation instructions.

Part Names and Functions	1-2
Front	1-2
Rear/side	1-3
Operating panel	1-4
Media sensor	1-6
Carriage	1-6
Cutter blade and cutting slot	1-6
Capping station	1-6
Pinch rollers and grit rollers	1-6
Connecting Cables	1-7
Connecting a USB 2.0 interface cable	1-7
Inserting Ink Cartridges	1-8
Precautions on handling ink cartridges	1-8
Inserting ink cartridges	1-9
Replacing ink cartridges	1-10
Ink cartridge lamps	1-10
Machine restrictions	1-10
Precautions on handling media	1-10
Assembling ink cartridges	1-11
Menu Mode	1-12

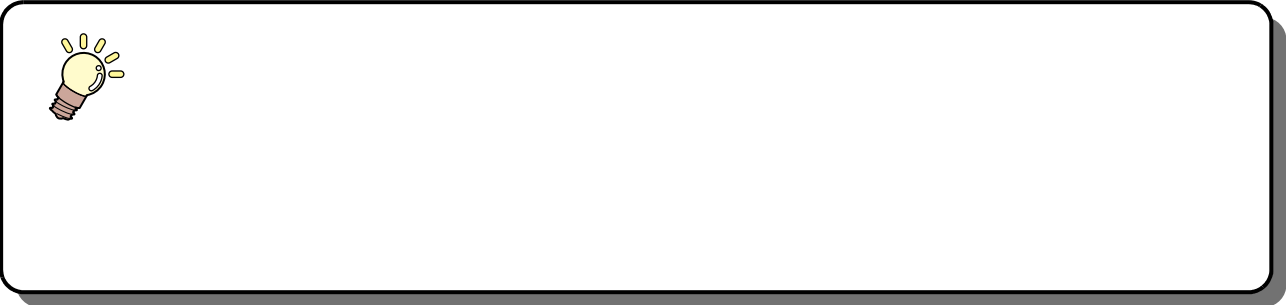

Part Names and Functions

Front

Ink cartridges

Each cartridge contains ink of a particular color.

Cartridge cover

Prevents injury or damage to the machine due to protruding ink cartridges. (located under ink cartridges)

Clamp lever (front)

Moves the pinch rollers up or down to hold or release the media.

Operating panel

Equipped with keys for operating the machine and an LCD that displays setting items.

Maintenance liquid cartridge slot

For loading washing liquid.

Carriage

Moves the print heads left and right to print.

Waste ink tank

Waste ink is collected in this tank.

Stand

Supports the machine. Equipped with casters for moving the machine.

Post-heater

Dries ink after printing.

Platen

Print area.

Maintenance cover

Opened for maintenance. Even when the power switch is off, keep all covers closed.

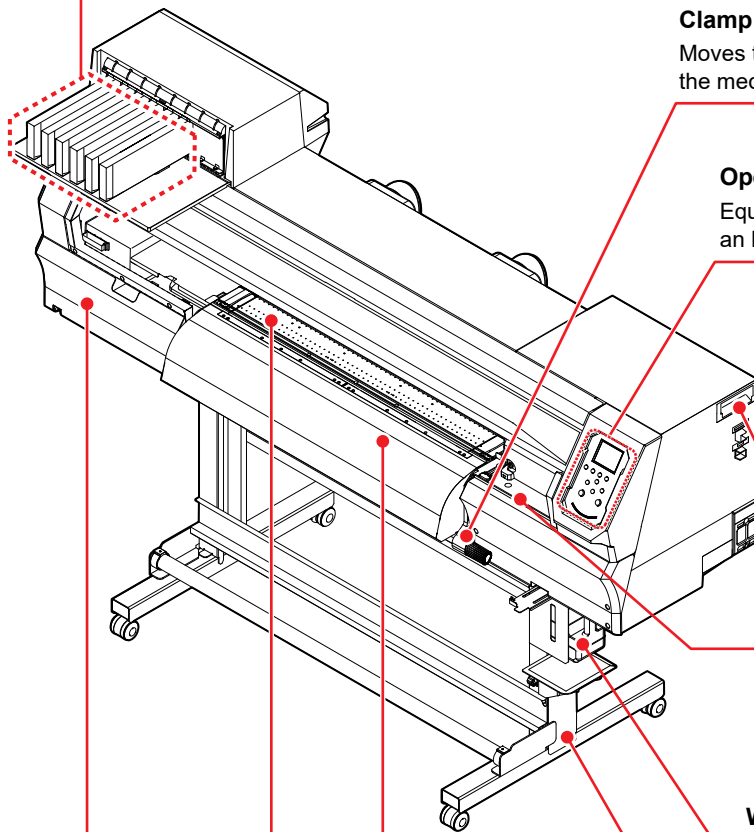

Rear/side

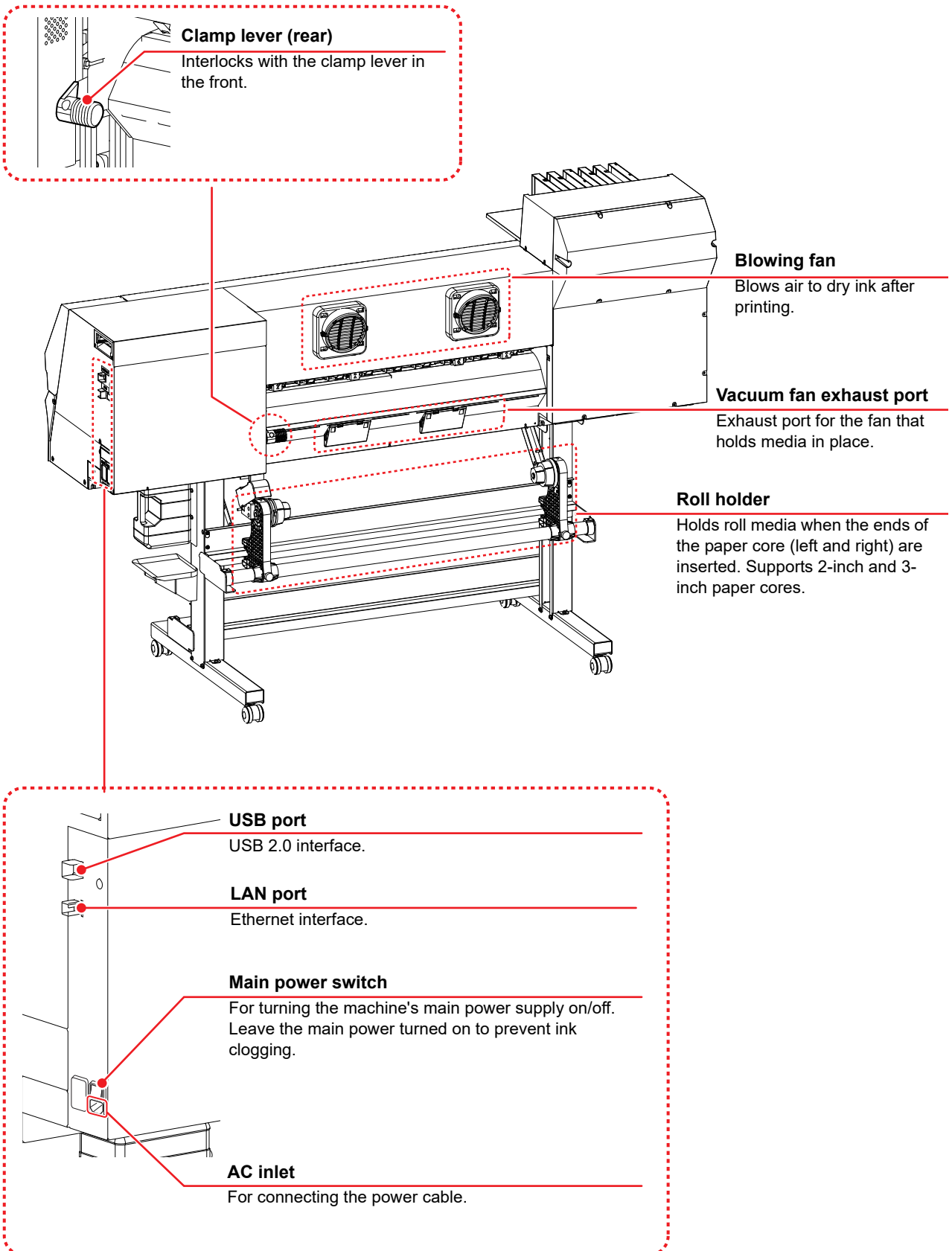

Illustration: TxF150-75

Operating panel

Use the operating panel to specify print settings or operate the machine.

[SEL] key

Switches the selected function.
Function ([FUNC1]–[FUNC3]) keys

Pressed to set various functions, perform test printing, etc.

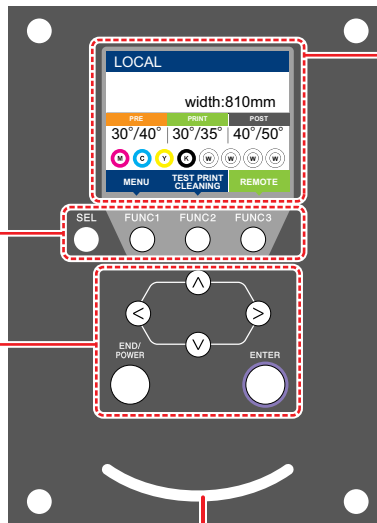

Display

Shows the following items:

- Machine status
- Width of loaded media
- Heater temperature (current/set temperature)
- Ink status^{*1}
- Functions assigned to [FUNC1]–[FUNC3]^{*2}

JOG keys

Used to move the carriage or media in local mode and to select setting items.

[END/POWER] key

Cancels the previously entered setting or returns to the previous level of the setting menu. Also used to turn the power on and, when held down, off.

[ENTER] key

Used to move to the next level of the setting menu or to confirm the setting value.

Status indicator lamp

Indicates the machine's status (printing, error, etc).

Lamp state	Machine status
Off	In local mode. No print data received, and no errors.
Lit in light blue	In remote mode.
Flashing light blue	Currently printing.
	Printing an internally stored pattern, as in test printing.
Lit in blue	Print data still remains in the machine.
Flashing red	An error has occurred.
Lit in red	An error (SYSTEM HALT) has occurred.
Purple or white Instantaneous flashing	Indicates the "circulating level" condition.
Lit in green	It is in circulation.



- Turning the machine on with the power switch illuminates the [END/POWER] key (near the bottom of the operating panel) in blue. As long as the main power switch (P.1-5) is on, auto maintenance is performed periodically (to prevent nozzle clogging, for example).

*1: Ink status

Ink status (such as remaining ink level or errors) is indicated by icons.

Icon	Details																		
	<ul style="list-style-type: none"> • The amount of ink left is indicated in nine levels with these icons. <table border="1" style="width: 100%; text-align: center;"> <tr> <td></td> <td></td> <td></td> <td></td> <td></td> <td></td> <td></td> <td></td> <td></td> </tr> <tr> <td>Ink full</td> <td>Approx. 1/8 used</td> <td>Approx. 1/4 used</td> <td>Approx. 3/8 used</td> <td>Approx. 1/2 used</td> <td>Approx. 5/8 used</td> <td>Approx. 3/4 used</td> <td>Approx. 7/8 used</td> <td>Near end</td> </tr> </table>										Ink full	Approx. 1/8 used	Approx. 1/4 used	Approx. 3/8 used	Approx. 1/2 used	Approx. 5/8 used	Approx. 3/4 used	Approx. 7/8 used	Near end
Ink full	Approx. 1/8 used	Approx. 1/4 used	Approx. 3/8 used	Approx. 1/2 used	Approx. 5/8 used	Approx. 3/4 used	Approx. 7/8 used	Near end											
	<ul style="list-style-type: none"> • Displayed when the machine is nearly out of ink. Very little ink is left, so have new ink ready. 																		
	<ul style="list-style-type: none"> • Displayed when ink is depleted or an ink error has occurred. Printing is not possible. 																		



Displayed when the ink has passed its expiration date. Replace with new ink or use up as quickly as possible. Printing is possible.

*2: Functions assigned to [FUNC1]–[FUNC3]

Details of functions assigned to [FUNC1]–[FUNC3] are described below.

Icon	Details
	<ul style="list-style-type: none"> Display a menu for setting functions.
	<ul style="list-style-type: none"> Display maintenance functions such as test printing or cleaning.
	<ul style="list-style-type: none"> Switch from local to remote mode and start printing.
	<ul style="list-style-type: none"> Display adjustment functions such as feed correction or dot position correction.
	<ul style="list-style-type: none"> Set the heater temperature.
	<ul style="list-style-type: none"> Clear data.
	<ul style="list-style-type: none"> Stop printing in remote mode and switch to local mode.
	<ul style="list-style-type: none"> Cut the media.
	<ul style="list-style-type: none"> Move to the previous page on screens (such as the menu screen) with multiple items.
	<ul style="list-style-type: none"> Move to the next page on screens (such as the menu screen) with multiple items.
	<ul style="list-style-type: none"> Used for confirming a warning message, etc. when displayed.
	<ul style="list-style-type: none"> Used to turn off or disable a function, such as deactivating the heater.
	<ul style="list-style-type: none"> Indicates that some setting or function has been assigned. Use the assigned setting or function as described in the instructions.
	<ul style="list-style-type: none"> Select/clear items when multiple items can be selected.



- Icon color varies depending on machine status.
 - Green: Machine is in remote mode.
 - Dark blue: Machine is in local mode.
 - Yellow: A warning has occurred.
 - Red: An error has occurred.

Media sensor

The media sensor detects when media is present and determines the media length. The machine is equipped with one media sensor, on the back of the platen.

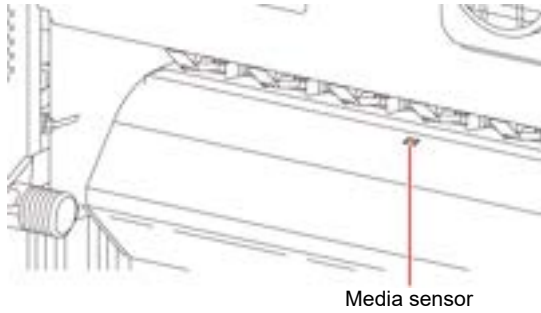

- Load media so that it covers the media sensor on the back of the platen. Media cannot be detected unless it is placed over the sensor.

Carriage

The carriage includes a print head for ejecting ink, and a jam sensor for stopping the carriage when media clogs. Printing occurs as ink is ejected while traversing left and right.

A lever is provided to adjust the head height in 3 levels to suit media thickness (☞ P.2-6 [Adjusting head height]).

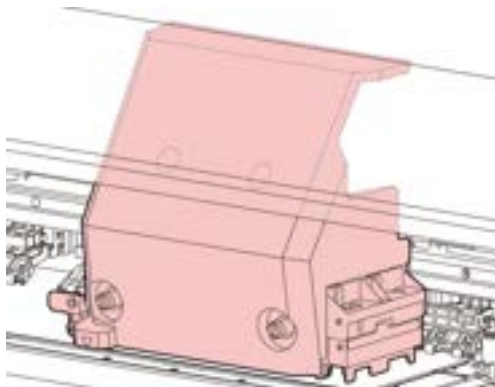

Cutter blade and cutting slot

The carriage is equipped with a media cutting unit. Media is cut along the cutting slot on the platen.

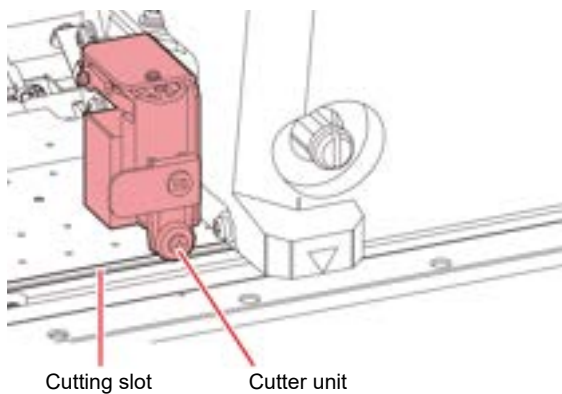

Capping station

The capping station consists of ink caps, a wiper for cleaning print heads, and other parts required for head maintenance.

The ink caps prevent the head nozzle surface from drying out.

The wiper is used to clean head nozzles. The wiper is a consumable. If it becomes deformed or media becomes soiled, replace the wiper with a new one.



- Always wear the included safety glasses when cleaning inside the capping station. This precaution is necessary to prevent ink from getting in your eyes.

[TxF150-75]

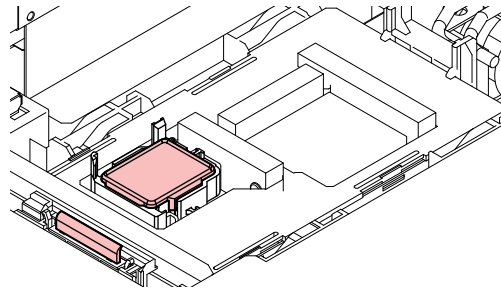

[TxF300-75]

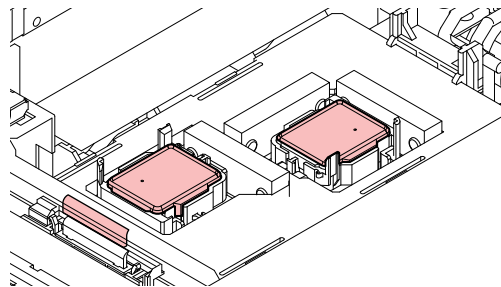

Pinch rollers and grit rollers

The pinch and grit rollers hold and feed media.

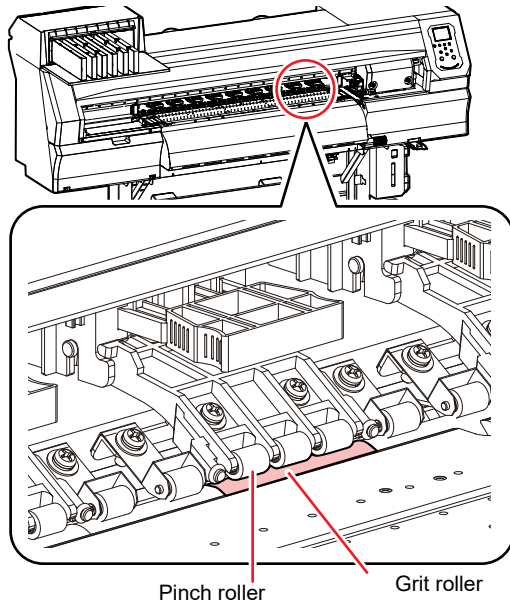

- When the machine is not in use, raise the clamp lever to separate the pinch rollers from the grit rollers. Leaving the pinch rollers in the lowered position for an extended period of time may cause the pinch rollers to become deformed. Deformation of the pinch rollers may prevent the media from being fed correctly.
- When using the machine, the clamps should be raised where the pinch roller and grit roller directly contact each other.

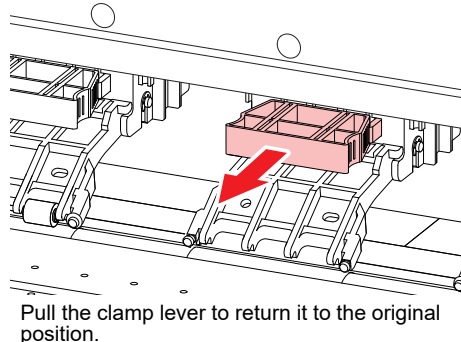
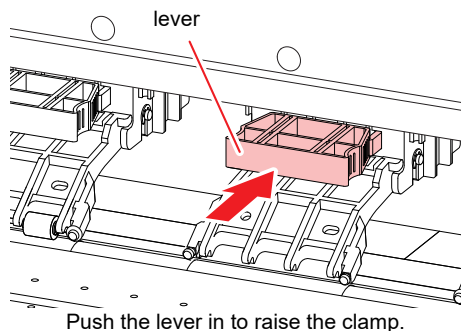

Connecting Cables

Connecting a USB 2.0 interface cable

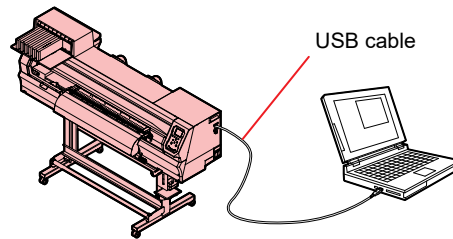

Use a USB 2.0 interface cable to connect the machine to a computer.



- If your computer does not have a USB port, contact a local RIP provider or our service office for assistance.

USB interface precautions



- Your RIP must be compatible with USB 2.0.

● When connecting more than one TxF150, TxF300 to a computer

When more than one TxF150, TxF300 is connected to a computer, the computer may not recognize the machines correctly.

If the computer has multiple USB ports, try connecting the machines to different USB ports and confirm that they are recognized correctly. If a TxF150, TxF300 is still not recognized after you switch USB ports, try using a commercially available USB extension cable.

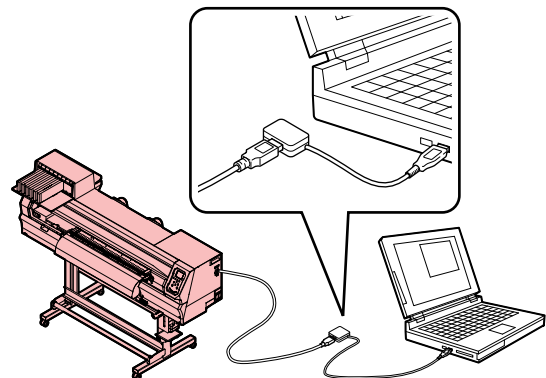

● USB High Speed peripherals

Using the machine with peripherals that operate in USB High Speed mode (such as USB flash drives or USB hard drives) may prevent the computer from recognizing the USB devices.

It may take longer to send print data when the machine is connected to a computer that is also connected to an USB hard drive or similar peripheral. Thus, this may cause the carriage to pause at the left or right end during printing.

● Disconnecting USB flash drives

Before disconnecting USB flash drives from computers that the machine is also connected to, click [Stop] in [Safely remove hardware].

Failure to observe these instructions may result in [Error 10 Command Error].

Copy the spool data to the hard disk before printing.



Connecting the power cable

1 Insert the power cable into the inlet on the machine.

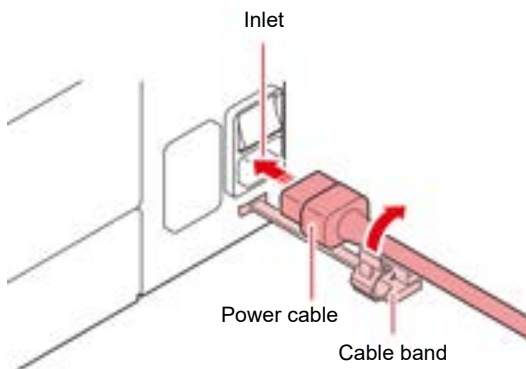

2 Secure the cable band.

- Secure the cable with the cable band attached to the machine.

3 Plug the power plug into a power outlet.

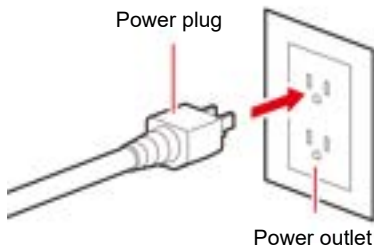

- Plug the power cable into a grounded outlet. Failure to observe these instructions may result in fire or electric shock.



- Use only the power cable supplied with the machine.



- Always plug the power cable into an outlet near the machine, and make sure the power cable can be easily unplugged.

Connecting a LAN cable

Connect a PC to this product using a LAN cable. Insert a LAN cable until it engages with a click.



- Do not unplug the cable while data is being transferred.

● Network Connection Precautions

Make sure the network is set up as follows: Printing is not possible if the network is not set up correctly.

- Use a Category 6 or higher LAN cable.
- The PC used to transfer print data must be located on the same network as this product. This product cannot be connected via a router.
- Use a 1000BASE-T compatible computer or switching hub. Printing requires 1000BASE-T support.

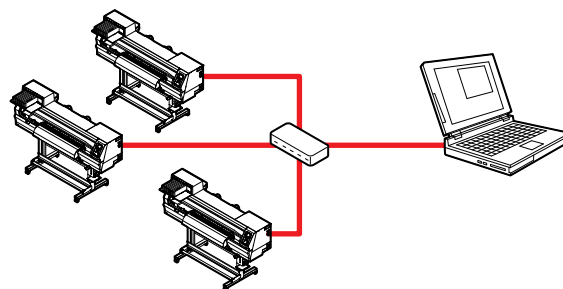

● Checking the LAN connection

1 Check the display on this product.

- Local guidance can be used for checking. Printing is not possible if "100Mbps", "10Mbps", or "No Connect" is displayed. Event email can be used.

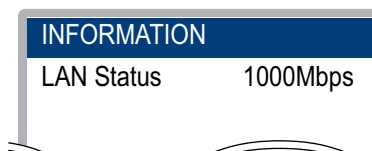

2 Check the lamp on the LAN connector.

- The LAN connector lamp illuminates when the machine is running.

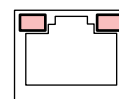

Color	Status	Overview
Green	Illuminated	Connected via 1000BASE-T
	Off	Connected via a network other than 1000BASE-T 1,000 Mbps is not supported if only the orange lamp is illuminated or flashing. Check the specifications for the PC, peripheral devices, and cable.
Orange	Illuminated	Linked up (connected).
	Flashing	Data being received
	Off	Link down (not connected)

Inserting Ink Cartridges

Precautions on handling ink cartridges



- Ink cartridges are labeled with precautions about the ink. Thoroughly read them and make sure you understand the contents.
- Before using ink and maintenance liquid, be sure to read the Safety Data Sheet (SDS) and instruction manual for ink. (<https://mimaki.com/supply/sds/>)
- Also be sure to use ink cartridges recommended by Mimaki.
- Keep ink away from open flame. Also, be sure that the room is well ventilated when using or handling ink.
- Immediately wipe off any ink, maintenance liquid, waste ink, or other liquid used with the machine that comes into contact with your skin using a cloth. Wash with soap and rinse with plenty of water. Failure to observe these instructions may result in skin inflammation. If your skin becomes irritated or painful, seek medical attention immediately.
- If ink, maintenance liquid, waste ink, or any other liquid used with the machine comes into contact with your eyes, rinse immediately with plenty of clean water. Rinse for at least 15 minutes. If you wear contact lenses and they can be easily removed, remove after rinsing for at least 15 minutes with clean water. Rinse thoroughly, including the undersides of your eyelids. Failure to observe these instructions may result in blindness or impaired vision. If your eyes become irritated or painful, seek medical attention immediately.
- If ink, maintenance liquid, waste ink, or any other liquid used with the machine enters your mouth or is swallowed, gargle with water immediately. Do not induce vomiting. Seek medical attention promptly. Inducing vomiting may cause liquid to enter the airway.
- If a large amount of vapor is inhaled, move to a well-ventilated area, keep warm, and rest in a posture that allows easy breathing. If the condition does not improve, seek medical attention promptly.
- The machine's safety rating is based on using ink recommended by Mimaki. To ensure safe operation, use ink recommend by Mimaki.
- If the ink cartridges are brought from a cold place to a warm place, leave them at room temperature for at least three hours before use.
- Open the ink cartridges just before installation. If they are left open over an extended period, it may not be possible to print normally.
- Store ink cartridges in a cool, dark place.
- Keep ink cartridges and waste ink tanks out of the reach of children.
- Once an ink cartridge is opened, use up the ink within one month. Printing quality declines after cartridges have been open over an extended period.

- Please hand over unused ink cartridges, ink packs, and waste ink to your dealer or service representative. If you dispose of them by yourself, comply with requirements of your industrial waste disposer and local regulations.
- Do not hit ink cartridges or shake them roughly. This may cause ink to leak from the cartridge.
- Do not attempt to refill ink packs or ink cartridges. Mimaki is not responsible for any problems caused by using refilled ink.
- Do not touch and avoid soiling ink cartridge PCB contacts. This may result in PCB failure.
- Do not disassemble ink cartridges.



Inserting ink cartridges

1 Gently shake the ink cartridge.

To prevent ink leakage when shaking the cartridge, wear gloves and firmly cover part A on the top of the cartridge and part B on the bottom with a paper towel or the like, and then rock the cartridge gently so that ink flows slowly from one end to the other.

*** White ink:40 times, All other ink:20 times**



- White ink should be shaken 100 times after more than 3 days.



Part A (opening for the needle)

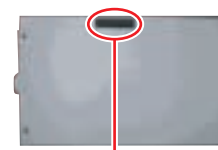

Part B (gap on the bottom)

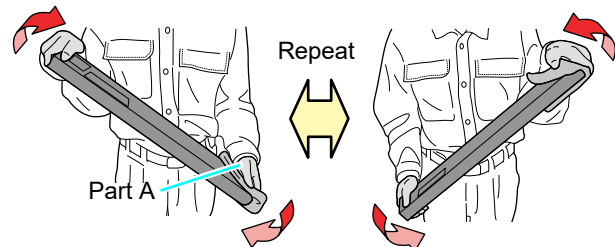

Hold firmly with a paper towel and gently shake



- Shaking too roughly may damage the internal pack, which may result in leaks.
- It may not be possible to agitate the ink well unless there is enough ink left. Tilt the cartridge until it is vertical.
- When using white ink:
This message is displayed after the machine has been on for 24 hours, or when it is turned on initially.
White ink should be shaken regularly, because the ink components are more likely to settle. Also be sure to shake it before printing.

Shake white cartridge[ENT]

- Ink in other colors should be shaken about once a week.P.4-4 [Ink maintenance]

2

Insert the ink cartridge.

- Insert the ink IC chip with it facing left.

[TxF150-75]

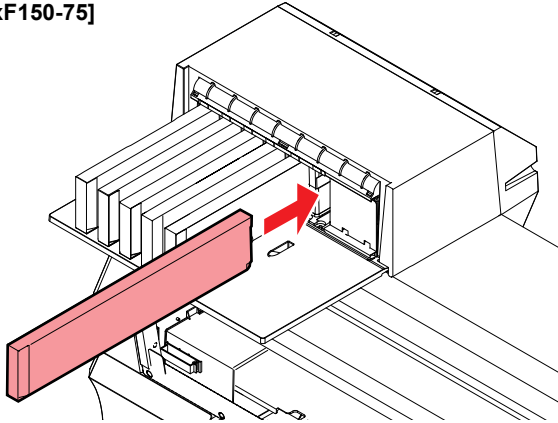

[TxF300-75]

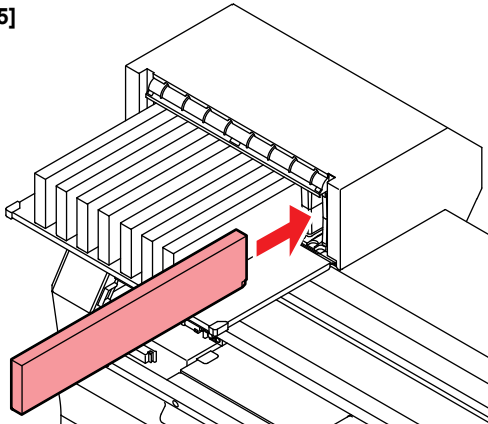

- Colors are indicated as follows on the display:
 - C: Cyan
 - M: Magenta
 - Y: Yellow
 - K: Black
 - W: White
- For details on the order of insertion, see P.6-5 [Order for Loading Ink Cartridges].
- Fully push in the eco-case. Otherwise, ink may not be fed properly.
- Do not touch the metal parts of the ink IC chip. Static electricity may damage the ink IC chip, and dirt or damage may make the ink IC chip unreadable.



When Ink Level Low or Ink Near End is Displayed

This machine counts the consumed ink amount. Discrepancies in actual consumed ink amount can occur for some reason. If the warning message appears, take appropriate actions as instructed on the operating panel.

LED	Message	Display condition*1	Machine operation		Corrective action
			Printing	Cleaning	
Lit in yellow	Ink level low	The ink remaining in the cartridge is below 60 ml.	Possible	Disabled	1. Remove the ink cartridge, and measure the weight. (☞ P.3-10 [Correcting the Ink Cartridge Case Weight]) 2. Enter the measured weight into the machine. (☞ P.3-10 [Correcting the Ink Cartridge Case Weight])
	INK NEAR-END	The ink remaining in the cartridge is below 60 ml after the weight of the cartridge is corrected.	Possible	Disabled	
Lit in red	Ink level end	The ink remaining in the cartridge is below 30ml.	Disabled	Disabled	1. Replace the ink pack. (☞ P.1-14 [Replacing Ink])
	Replace Inkpack (Ink End)	The ink remaining in the cartridge is below 30 ml to 36 ml after the weight of the cartridge is corrected.	Disabled	Disabled	

*1. The remaining ink amount is only a guide.

When Replace Inkpack (Ink End) is Displayed

The ink has run out. Replace with new Ink pack.

Thoroughly read the following and make sure you understand its contents.



- Pay close attention to ventilation and be sure to wear safety glasses, gloves, and a mask when handling ink, maintenance liquid, waste ink, or other solutions used with the machine. Leaking ink may adhere to the skin or get into the eyes or mouth.



- The ink in the ink pack cannot be used up completely. The ink pack is filled up with the amount of ink which is slightly more than the indicated value. When [Ink End] or [Replace Inkpack] is displayed, the ink is not completely used up and a small amount of ink remains.

Ink cartridge lamps

The lamps above ink cartridges indicate the status of the loaded cartridges.

[TxF150-75]

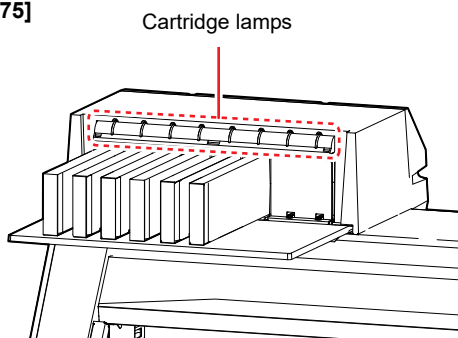

[TxF300-75]

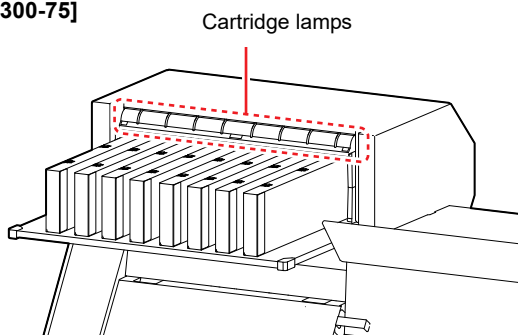

Lamp status	Description
Lit in green	Normal (ink is being supplied)
Off	No error
Lit or flashing in yellow	One of the following errors has occurred: <ul style="list-style-type: none"> • Ink near end • Ink end • Ink expired (1 month past)
Flashing red	Ink expired (2 months past)
Lit in red	One of the following errors has occurred: <ul style="list-style-type: none"> • No ink cartridge inserted • Other ink errors (P.5-5 [Ink errors])
Flashing green	Circulating operation is in progress. Never remove the cartridge.

Machine restrictions

The ink expiration date is indicated on the ink pack. Expired ink may cause ejection failures or alter the color tone. Printing is possible even if the ink has passed its expiration date. Nevertheless, we recommend replacing with new ink or using up as quickly as possible.

Example: When the expiration date is April

May: Replace with new ink or use up as soon as possible. Printing is possible.

June (lamp lit in yellow): Replace with new ink or use up as soon as possible. Printing is possible.

July (lamp flashing red): Printing is not possible.

Important! • The message appears on the display.

Replacing Ink



• When replacing with a new 600 ml ink cartridge case, register the case weight. (P.3-9 [Replacing with a New Ink Cartridge])



• When replacing with a new ink pack, the cartridge weight does not need to be entered. (P.3-10 [Correcting the Ink Cartridge Case Weight])

● Removing the Ink cartridge

1 Remove the ink cartridge.

[TxF150-75]

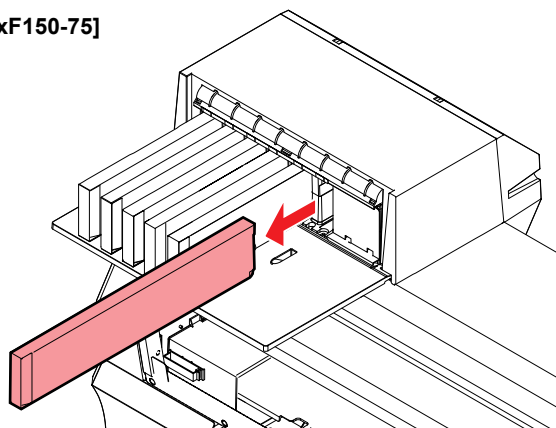

[TxF300-75]

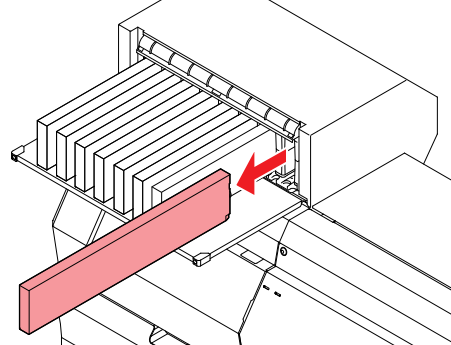

• When disposing of the product, contact an industrial waste disposal operator or dispose of the product in accordance with the local laws and regulations.

● Replacing Ink Pack

1 Press the case tab with a finger to open the lid.



2 Remove the old ink pack.

3 Place a new ink pack inside the ink cartridge case.

- Push the ink pack connector into the ink cartridge case slot with the double-sided tape attached side facing down. Ink may not be supplied if the connector is out of position.



- The "Law Booklet" supplied with the packs should be placed in the packs without removing it.

4 Adjust the shape of the ink pack.



5 Remove the seal of the double-sided tape.



6 Secure the ink pack so that it will not become loose.



- When securing the ink pack, be sure to secure it so that there is no bias within the ink cartridge case.

Good example



The ink pack is aligned with the corner of the case

Bad example

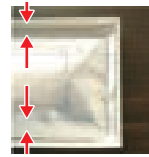



The ink pack is inclined







The corners of the ink pack and the case are not aligned

7 Replace with a new ink IC chip.

- Slide to the side to remove.

Good example	Bad example	
	 <p data-bbox="379 427 539 483">Front and back are reversed</p>	 <p data-bbox="584 427 743 510">Inserted incorrectly left-to-right</p>

Ink Color	Marking	
Cyan		(One blue circle)
Magenta		(One red circle)
Yellow		(One yellow circle)
Black		(One black circle)
White		(One white circle)

8 Close the case lid.

- Push in until the tab clicks.



- Be careful to avoid catching your hands or fingers.

Menu Mode

The machine has four modes. Each menu mode is described below.

Not-Ready mode

The machine is in this mode before detection of media.

Local mode

In this mode, the machine is ready to print. All keys are available. The machine can receive data from a computer.

The following operations are available in local mode:

- Pressing the jog keys to set the print origin and print area.
- Checking remaining ink levels, cartridge error details, the model name, firmware version, and so on by pressing the [Enter] key.

Screen display in local mode

Shows the current heater temperature.

Icon color above the temperature varies depending on the current heater status.

Orange: Temperature rising

Green: At the specified temperature

Gray: Heater off

Shows the functions assigned to function keys [FUNC1]–[FUNC3].

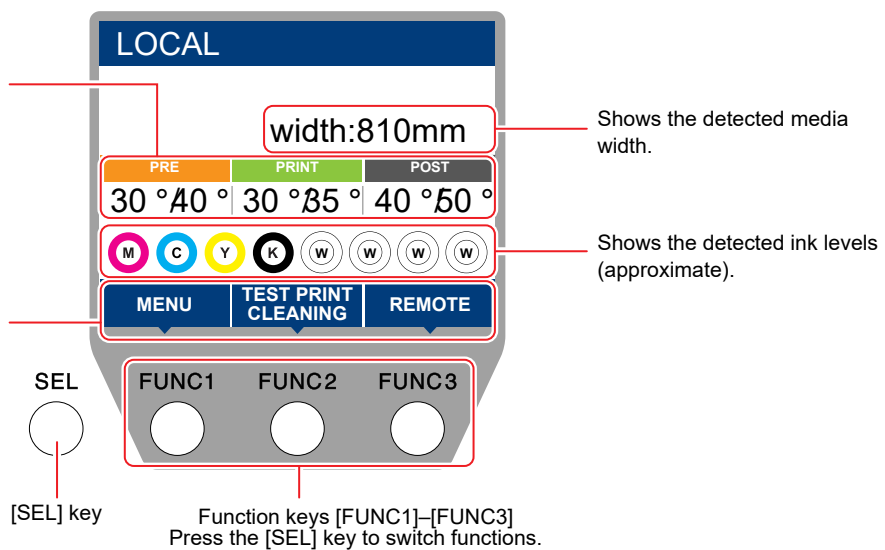

Menu mode

To enter menu mode, press the [FUNC1] key in local mode. This mode enables you to set each function.

Remote mode

In this mode, the machine prints data it receives.



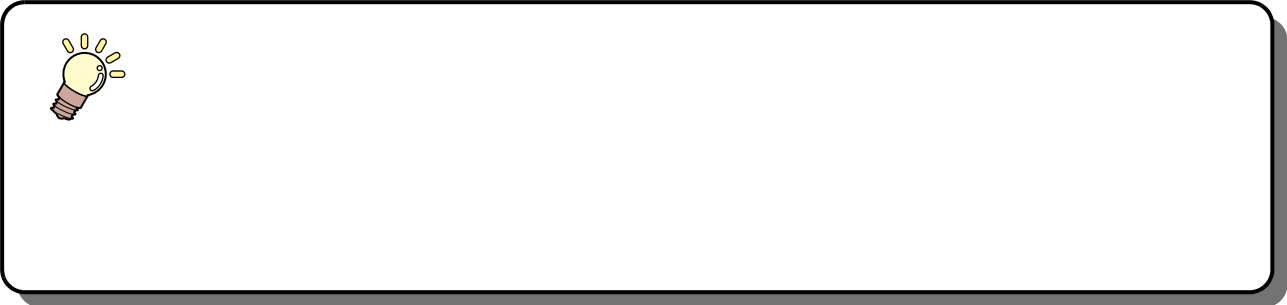

Workflow	2-2	Performing head cleaning based on test printing results	2-9
Turning the Power On/Off	2-3	Feed Correction Settings	2-10
Turning the power on	2-3	Feed correction	2-10
Turning the power off	2-3	If the Positions of Dots Shift	2-11
Loading Media	2-4	Printing Data	2-11
Adjusting head height	2-4	Starting printing	2-11
Loading roll media	2-5	Pausing printing	2-12
Changing the printing origin	2-7	Clearing received data (Data Clear)	2-12
Preparing the Heater	2-8	Cutting media	2-12
Changing heater temperature settings	2-8		
Test Printing	2-8		
Test printing	2-9		
Head Cleaning	2-9		
About head cleaning	2-9		

Chapter 2 Basic Operations



About this chapter

This chapter describes ink and media preparation, printing procedures, and setting methods.

Workflow	2-2	Performing head cleaning based on test printing results	2-9
Turning the Power On/Off	2-3	Feed Correction Settings	2-10
Turning the power on	2-3	Feed correction	2-10
Turning the power off	2-3	If the Positions of Dots Shift	2-11
Loading Media	2-4	Printing Data	2-11
Adjusting head height	2-4	Starting printing	2-11
Loading roll media	2-5	Pausing printing	2-12
Changing the printing origin	2-7	Clearing received data (Data Clear)	2-12
Preparing the Heater	2-8	Cutting media	2-12
Changing heater temperature settings	2-8		
Test Printing	2-8		
Test printing	2-9		
Head Cleaning	2-9		
About head cleaning	2-9		

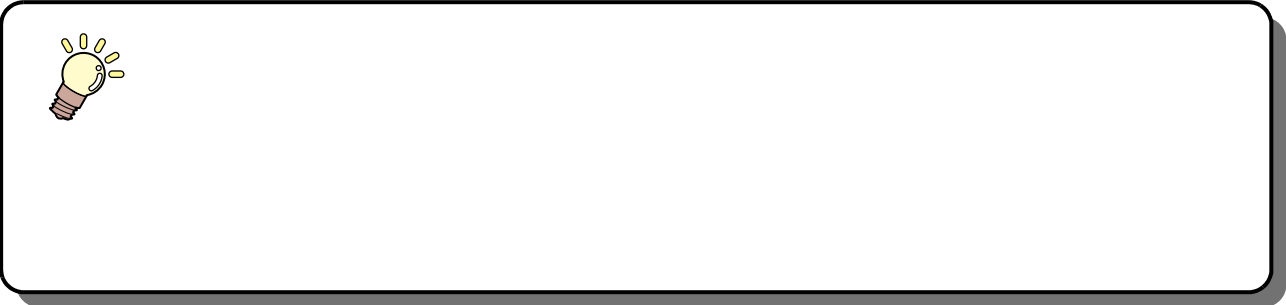

Workflow

1 Turning the Power On/Off

See 「Turning the Power On/Off」 (🔗 P.2-5).

2 Loading Media

See 「Loading Media」 (🔗 P.2-6).

3 Test Printing

See 「Test Printing」 (🔗 P.2-10).

4 Head Cleaning

See 「Head Cleaning」 (🔗 P.2-11).

5 Printing Data

See 「Printing Data」 (🔗 P.2-13).

Turning the Power On/Off

Turning the power on

The machine has two power switches.

[END/POWER] key:

Normally, use this key to turn the power on or off.

Main power switch:

On the side of the machine.



- Do not turn off the main power supply. Turning off the main power supply will disable the automatic maintenance function (including nozzle clogging prevention function and ink discharge channel cleaning function). This increases the risk of ejection failures (such as nozzle clogging or deflection).

1

Turn the main power switch on.

- The firmware version is displayed when the power is turned on, and initial operations are performed.

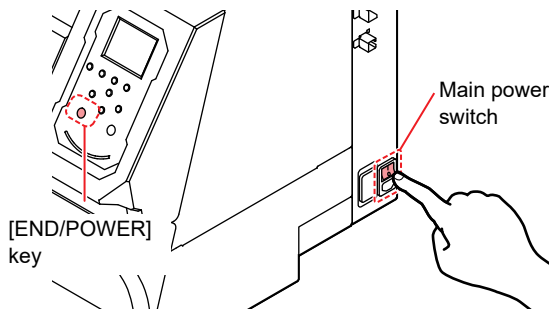

2

Press the [END/POWER] key to turn on power.

- The machine enters local mode.

3

Turn on the connected computer.



- Make sure the maintenance cover is closed before turning the machine on.

Turning the power off

After using the machine, press the [END/POWER] key on the front to turn it off.

Before turning the machine off, check the following:

- If the machine is receiving RIP data from the computer, or if any data has not been printed yet
- If the carriage has returned to the capping station
- If any errors have occurred (P.5-6 [Error messages])

1

Turn off the connected computer.

2

[END/POWER] key a long press.

- “ Turn off power?[ent] ” is displayed.

3

Press the [ENTER] key.

- Do not turn off the main power switch on the side of the machine.
- To use the machine again, press the [END/POWER] key.

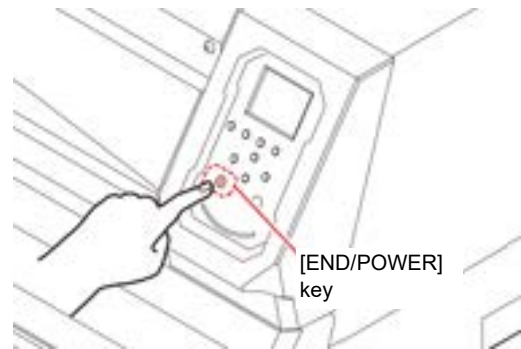

Precautions on turning the power off

● Do not turn the main power switch off.

Turning off the main power switch will prevent automatic maintenance from working, which may result in nozzle clogging.

● Check the carriage position before turning the machine off.

Turning the power off without the carriage returned to the capping station may result in the head nozzle surface drying out, which is a factor for nozzle clogging. In this case, turn the machine on again and confirm that the carriage has returned to the capping station before turning the machine off.

● Do not turn the power off during printing.

This may prevent the head from returning to the capping station.

● Press the [END/POWER] key to turn off the power before turning off the main power switch.

If you must turn off the main power switch when moving the machine or clearing an error, be sure to hold down the [END/POWER] key on the front and confirm that the operating panel display is off before turning off the main power switch.

Loading Media

The machine is designed to use roll media.
 For details on compatible media, see P.6-2 [Specifications].



- When loading roll media, be careful not to drop it on your feet or other body parts. Failure to observe these instructions may result in injury.
- At least two people must work together to load roll media. Working alone may result in back injury from the weight of rolls.



- Adjust the head height before loading media. Adjusting the head height after loading media may result in jamming, reduced print quality, or head damage.

Adjusting head height

Adjust the head height to suit media thickness.

1 Move the carriage over the platen.

- When the machine is on: Execute [ST.MAINTENANCE - CARRIAGE OUT] (maintenance function).
- When the machine is off: Move the carriage manually.

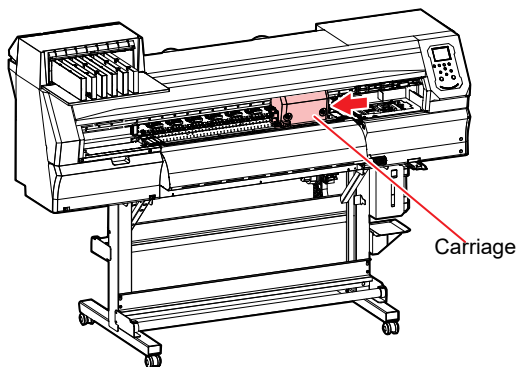

2 Loosen the screws on the front.

- Loosen the screws, rotating each by one turn using a flathead screwdriver.

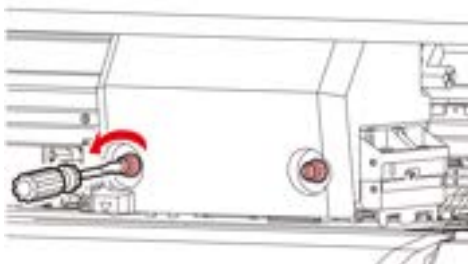

3 Adjust the height adjustment lever to suit the media.

- Referring to P.2-6 [Adjustment lever and range], adjust the position of the lever.
- Ensure that the height adjustment lever is set to the upper or lower position. Setting it to an intermediate height will cause printing errors.

Height adjustment lever

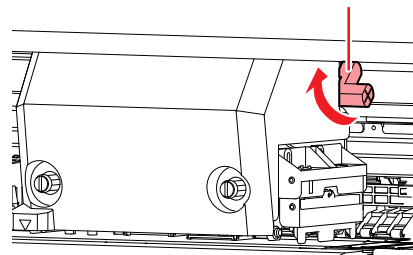

4 Fix the carriage.

- Tighten the screws securely so that they do not loosen.



- When you have set the height adjustment lever to the L or H range, do not press the height adjustment lever down or up when tightening the screws.

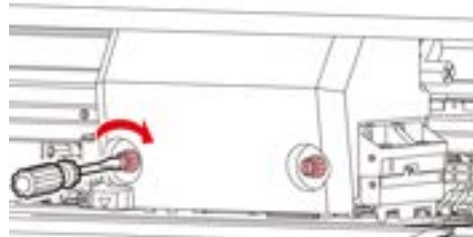

5 Return the carriage to the station position.

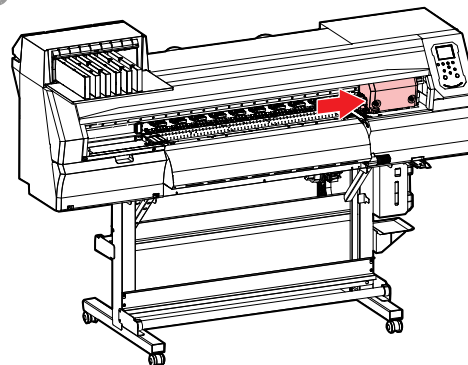

Adjustment lever and range

Range	Head height	Remarks
L range (recommended)	2 mm (position set as shipped)	The base of the head height can be raised by 1–2 mm.
M range	2.5 mm	Contact a Mimaki sales representative for details.
H range	3 mm	



- Mist is more likely to be generated when the "M range" or "H range" is used.

Loading roll media

Load roll media on the roll media hanger on the rear of the machine.

1 Move the roll holder located at the rear of the machine toward the middle of the machine.

- Before moving the holder, loosen the roll holder retaining screw.

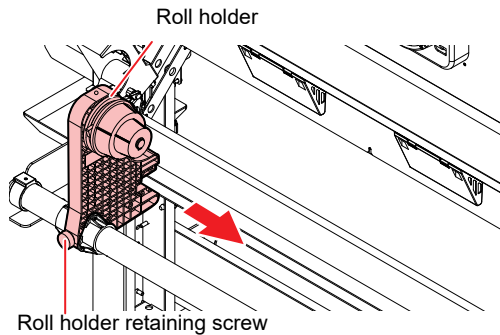

2 Confirm that the clamp lever is lowered.

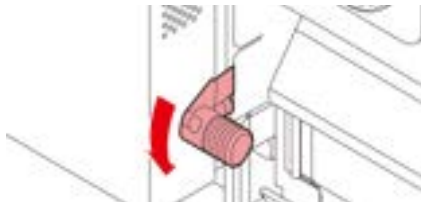

3 Move the roll holder to the roll loading position.

- Make sure the roll stopper is not caught between the roll stopper arm and the machine.

Roll holder side (rear of machine)

- Two internal diameters of paper cores are supported for roll media: 2 and 3 inches.
- Set the roll holder reference line within the area indicated by the arrows as shown below.

Roll Holder Set Position	3 Inch Roll Media	◀	▶
	2 Inch Roll Media	◀	▶

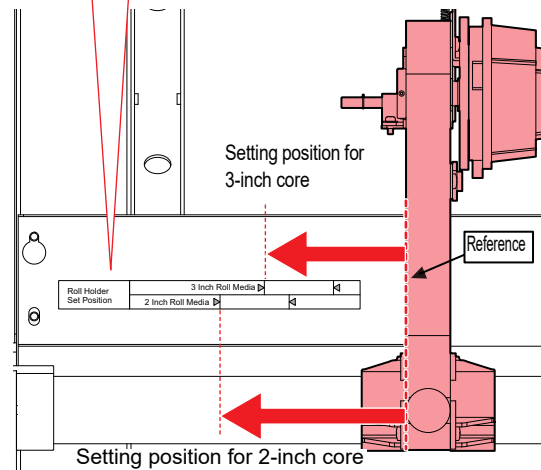

If the roll holder is set out of this range, media tension will not be applied when the media is pulled out by hand.

4 Tighten the roll holder retaining screws.

- Check steps 2–3 again.

5 Push the core of the roll media onto the left side of the roll holder.

- Push the roll media fully onto the roll holder until it is held securely.

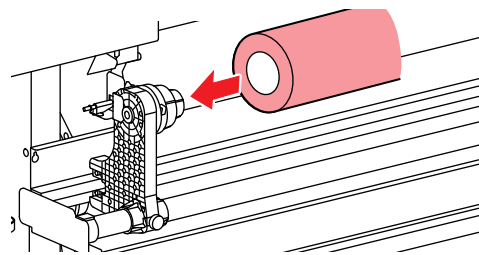

6 Loosen the screw on the right end of the roll holder and push the holder into the core of the roll media.

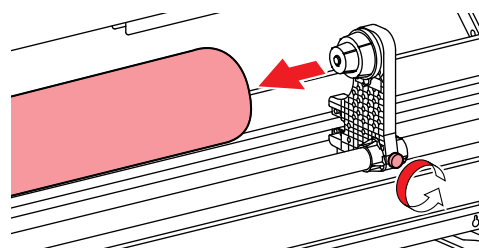

7 Raise the clamp lever on the rear of the machine.

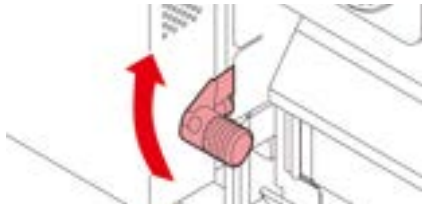

8 Insert the roll media into the machine.

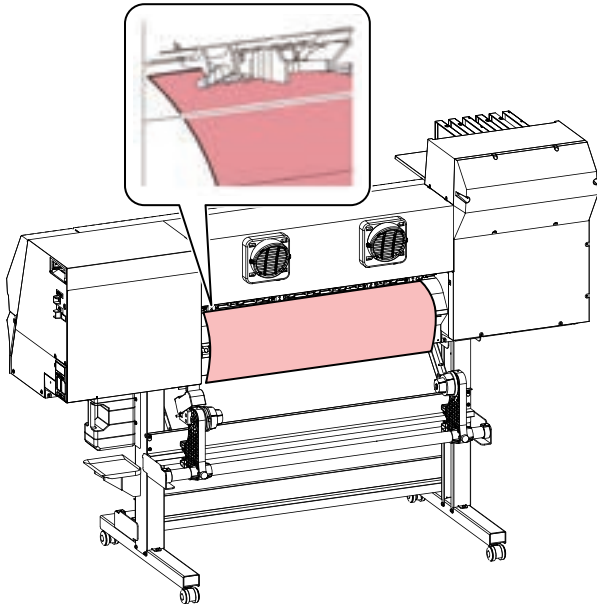

- Slightly tilt the media so that it can be smoothly inserted into the machine without catching on anything.

- (1) Pull the media out to around the front edge of the platen.
- (2) Insert the media between the platen and the pinch rollers.
 - Pull the media out of the roll so that it can be grasped from the front of the machine.
- (3) Lower the clamp lever on the rear of the machine.
 - This holds the media in place.

9 Pull out the roll media.

- (1) Raise the clamp lever on the front of the machine.
- (2) Gently pull out the roll media until the locking mechanism is engaged a little.

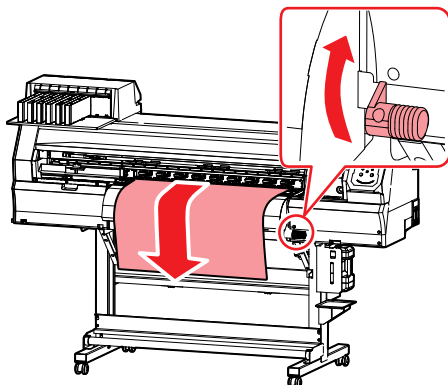

10 Make the roll media even, and then lower the clamp lever.

- Pull out a little at several positions of the media as needed to confirm that the amount pulled out is essentially even, and then lower the clamp lever.



11 Use the media holder to hold the media in place lightly.

- Position the media so that it does not protrude on the right end beyond the rightmost pinch roller.
- When using thick media, remove the media holder from the media before printing.

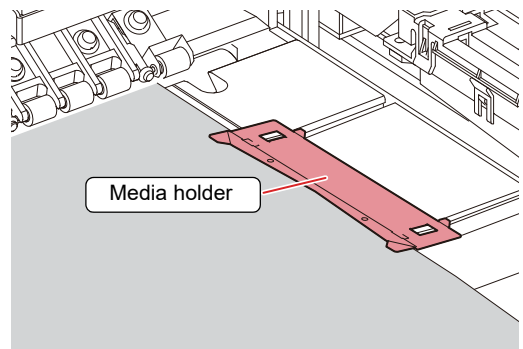

- When loading media, align the right edge with the platen groove. Placing media farther right than the groove will make it rise up if it moves obliquely, which may damage the head.
- An error message (MEDIA SET POSITION R) is displayed if media is misaligned to the left or right of the standard position. Reposition the media.

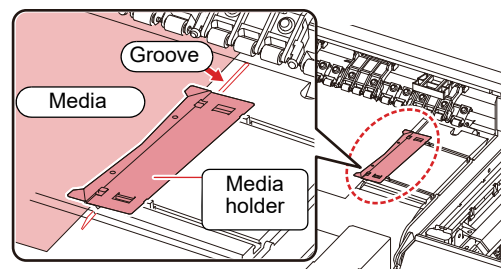

- When there is no media, use the pinch rollers with the clamp changeover sliders pushed back and the clamp raised. If pinch rollers press against the grit roller during transport, the roller surface may be damaged, which may result in transport problems and image quality problems from roller marks.

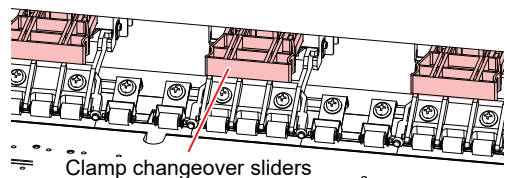

12 Press the [◀] key to detect the media.

- The media width is detected.
- When the [MEDIA RESIDUAL] maintenance function is set to "ON" (☞ P.3-9 [Setting remaining media display]), a screen for entering the remaining amount of media is displayed after media width is detected.

Entering the remaining amount of media

When you have set the [MEDIA RESIDUAL] maintenance function to "ON" (☞ P.3-9 [Setting remaining media display]), after media width is detected, a screen is displayed for entering the remaining amount of media.

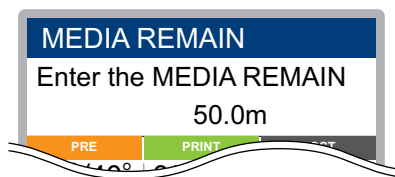
1 Display the screen for entering the remaining amount of media.**2** Press the jog keys to enter the amount of media remaining.**3** Press the [ENTER] key.**Printing information about the remaining amount of media**

When you have set the [MEDIA RESIDUAL] maintenance function to "ON" (☞ P.3-9 [Setting remaining media display]), you can print a list of the current date and remaining amount of media.

1 With the screen in local mode, press the jog keys.

- The machine enters origin setup mode.

2 Press the [FUNC3] key.

- A confirmation screen is displayed for printing the remaining amount of media.

3 Press the [ENTER] key.

- The machine begins printing information about the remaining amount of media.

Changing the printing origin

The position of the print origin can be changed.

Move the LED pointer to the new position to determine the position.

1 With the screen in local mode, press the jog keys.

- The machine enters origin setup mode.

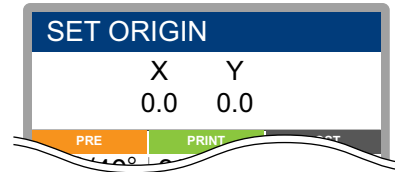
**2** Press the jog keys and align the light point of the LED pointer with the new printing origin to set.

- Select by moving the carriage and media.

3 After determining the origin, press the [ENTER] key.

- The origin is updated.

Guidelines for setting the origin position

In the depth direction (X'), the printing origin should be about 75 mm back from the cutting slot on the platen.

In the scanning direction (Y'), the printing origin should be 15 mm from the right edge of the media. This can be changed in the [MARGIN] setting menu (☞ P.3-5 [Margin (left/right)]). It can also be changed using the jog keys.

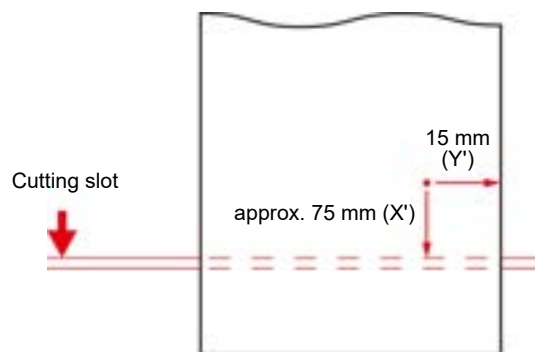

Preparing the Heater

Changing heater temperature settings

Set the heater temperature to suit the type and characteristics of media used. The temperature can be altered while printing is in progress, but this may cause color variations to occur.



- Adjust the heater temperature to suit the media type and characteristics. Depending on the type, the media may expand or shrink or become rippled.



- The temperature setting in the RIP software takes precedence. If you are using the Mimaki RIP software (RasterLink), the recommended values are stored in the color profile.
- It may take several minutes to several tens of minutes to reach the specified temperature, depending on the ambient temperature.
- By default, the heater temperature is set to "OFF."
- The heater temperature set here is stored in the "Heater" setting menu (P.3-4 [Heater]).

Type of heater	Function
Preheater	Preheats the media before printing to suppress rapid temperature change.
Print heater	Helps prevent ink bleeding.
Post-heater	Allows ink to dry after printing.

1 On the LOCAL mode screen, select [HEATER].

- The heater temperature adjustment screen is displayed.

2 Enter the heater temperatures, then press the [ENTER] key.

- Heater selection:** Select with [▲]/[▼]
- Temperature setting:** Set with [◀]/[▶]
- The heater now begins to heat up. The heater icon on the display turns green when the heater temperature reaches the specified level.



- The machine can be used in an environment of 20–30°C. Some ambient temperature conditions may prevent the machine from reaching the specified temperature.



- To fully deactivate heating, press [FUNC3] (OFF) in step 2. You can also increase all heating temperatures by 10°C by pressing [FUNC1].

Test Printing

Print a test pattern to check for nozzle clogging or other discharge defects (such as nozzle clogging or nozzle deflection).

Relationship of test patterns to head rows

Printing positions in test patterns are related to the head array as follows.

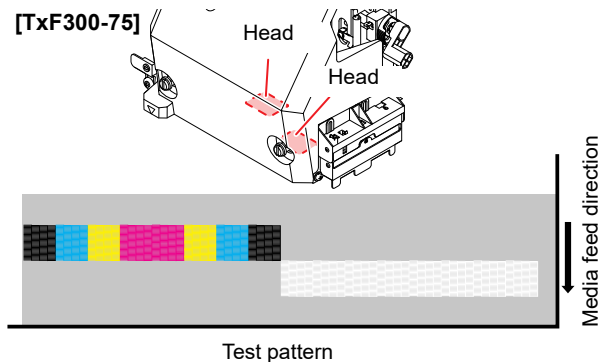
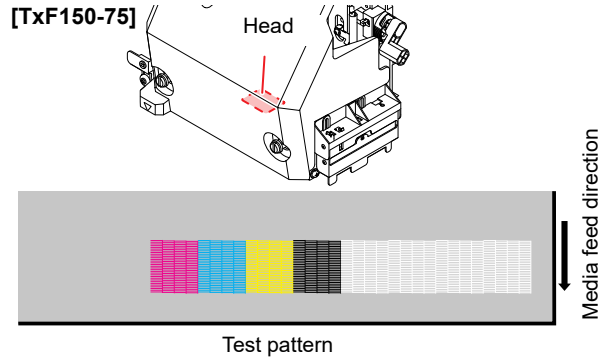

Test printing precautions



- When using roll media, manually rewind the media before printing to keep it taut. Failure to observe these instructions may result in image quality problems.

Test printing

Two options are available for the test pattern orientation. Select the option that suits your purpose.

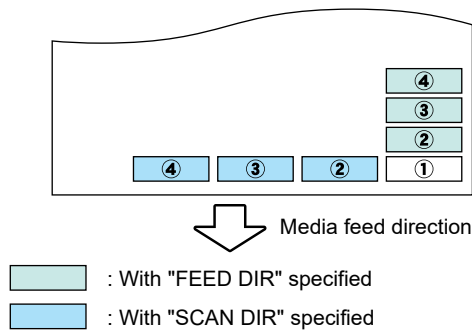

Check before test printing

- Media is loaded P.2-6
- The origin is set
- The head gap has been adjusted P.2-6

1 With the screen in local mode, select [TEST PRINT/CLEANING] > [Test Print], and then press the [ENTER] key.

- The Test Print menu is displayed.
- To change the test pattern orientation, press [▲]/[▼]. Any changes to the orientation here apply from now on.
- If you change the orientation to "FEED DIR.", after test printing with "SCAN DIR." the second pattern will be printed after a line break.

2 Press the [ENTER] key

- Test printing starts.

3 Check the printed test pattern.

- This process is finished if the results are normal.
- In case of abnormal results, perform head cleaning (P.2-11 [Head Cleaning]).

Normal pattern

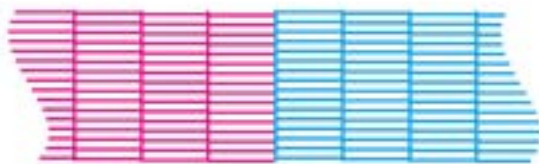

Abnormal pattern

Nozzles are not clean

Ink is clogged

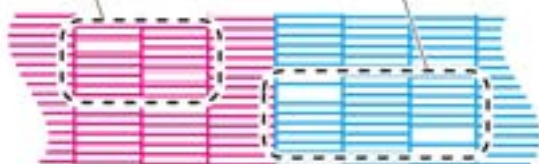

Head Cleaning

About head cleaning

Perform the type of cleaning that corresponds to the results of printing the test pattern.

Select one of the following four types of cleaning.

- **NORMAL**: When lines are missing
- **SOFT** : When only head wiping is needed (when lines are not straight)
- **HARD** : When poor image quality cannot be improved by normal or soft cleaning

Performing head cleaning based on test printing results

Three types of head cleaning are available. Choose one based on how the pattern is printed.

1 With the screen in local mode, select [TEST PRINT/CLEANING] > [Test Print], and then press the [ENTER] key.

- The cleaning menu is displayed.

2 Select the type of cleaning, and then press the [ENTER] key.

- The head is now cleaned.

3 Run another test print and check the print results.

- Repeat the cleaning and test printing process until the print results appear normal.



- Do the following if head cleaning fails to resolve print defects such as nozzle clogging or deflection.

- P.4-4 [Cleaning the wiper and cap]
- P.4-8 [Cleaning head nozzles]

Feed Correction Settings

You can correct the media feed amount by printing a correction pattern. Correct the media feed amount to suit the type of media you are using. Unsuitable correction values may result in banding or other printing problems.



- Roll media at the rear of the machine will not be taut after you perform feed correction and the media returns to the print origin. Manually rewind roll media before printing to keep it taut. Failure to observe these instructions may result in image quality problems.

Feed correction

You can correct the media feed amount by printing a correction pattern.

- 1 Load the media.**
 -  P.2-6 [Loading Media]
- 2 With the screen in local mode, select [ADJUST].**
 - The adjustment menu is displayed.
- 3 Select [FEED COMP.], and then press the [ENTER] key.**
- 4 Press the [ENTER] key to print the correction pattern.**
- 5 Check the correction pattern.**
 - A screen for entering the correction value is displayed

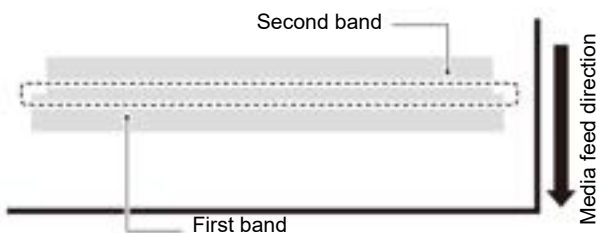

- Two bands are printed in the correction pattern. Adjust the feed amount so that the boundary between the bands has an even density.

- 6 Enter a correction value.**
 - **Entering positive correction values:** Widens the boundary between bands.
 - **Entering negative correction values:** Narrows the boundary between bands.
 - Changing the correction value by 30 adjusts the boundary width by about 0.1 mm.
- 7 Press the [ENTER] key.**
 - Print another correction pattern to check.

Correcting media-feeding during printing

You can correct the media feed amount even in remote mode or during printing.

- 1 Press [ADJUST] while printing is in progress**
- 2 Enter the correction value, and then press the [ENTER] key.**
 - **Correction value:** -9999 to 9999
 - The value entered here is immediately applied to the correction value.
- 3 Press the [ENTER] key.**
 - Your modified value is registered.
 - Corrections made here are only effective temporarily if you press the [END] key instead of the [ENTER] key. (The correction value is cleared when media is detected again, or when the machine is turned off.)

If the Positions of Dots Shift

Changing the media and print head height and temperature changes around the print head will also alter the drop positions. Correct the drop position to suit the type of media used. Image defects (e.g., overlaid lines or blurred images) will result if the drop position is not properly corrected.

Dot position correction

1 Load the media.

- P.2-6 [Loading Media]
- Printing a pattern requires media at least 500 mm wide.

2 With the screen in local mode, select [ADJUST].

- The adjustment menu is displayed.

3 Select [DROP.POScorrect] and press the [ENTER] key.

- The pattern for correcting the drop position is now printed.
- Multiple test patterns are printed, which are referred to by the order of printing (1, 2, 3, and so on).

4 Enter the correction value for pattern 1, and then press the [ENTER] key.

- **Correction value:** -40 to 40
- The position where the outward and return lines form a single straight line indicates the correction value to use.
- If the correction value to use does not lie in the range of -40 to 40, adjust the printing head height and repeat this process from step 2.

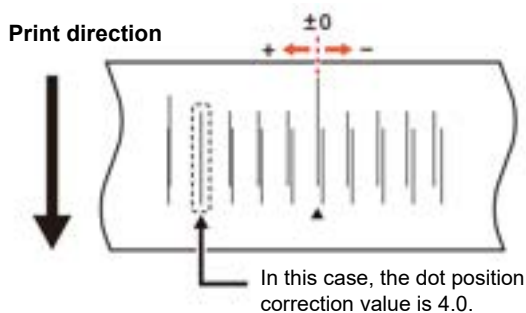

5 Do the same to enter a correction value for pattern 2, and then press the [ENTER] key.

Printing Data

Starting printing



- When using roll media, manually rewind the media before printing to keep it taut. Failure to observe these instructions may result in image quality problems.

1

Load the media.

- P.2-6 [Loading Media]

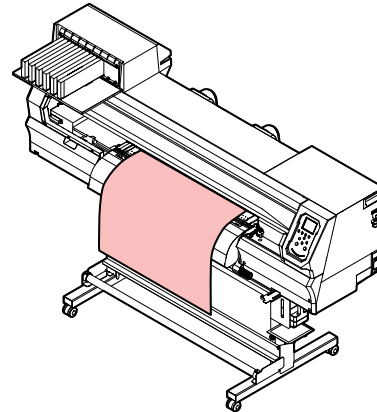

2

With the screen in local mode, press [REMOTE].

- The machine enters remote mode and can receive data from a computer.

3

Send the RIP data from the computer.

- Printing now begins. Even for the same data, printing speed varies depending resolution, media width, and print origin position.
- The ACTIVE lamp flashes, and the display shows print conditions.
- For details on how to send data, refer to the RIP software instruction manual.

Resolution

360 / 540 / 720 / 1440 DPI

Number of passes

Scanning direction

Uni: Unidirectional

Bi: Bidirectional

Scanning speed

Std: Standard speed

Hi: Double speed

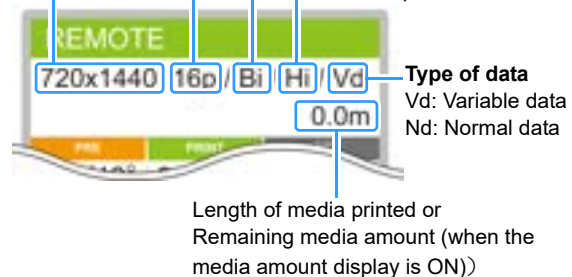

Pausing printing

- 1** Press [LOCAL] while printing is in progress.
 - Printing is paused.
 - If data is being sent from a PC, data transmission is paused at the PC.
 - Press the [REMOTE] key again to resume printing from the point at which it stopped.
- 2** Press [REMOTE].
 - Printing resumes.

Clearing received data (Data Clear)

To stop printing, clear the data received.

- 1** With the screen in local mode, select [DATA CLEAR].
- 2** Press the [ENTER] key to clear the received data.
 - The receive buffer is cleared.

Cutting media

You can cut media at any position by using the keys on the operating panel.

- 1** With the screen in local mode, press the jog keys.
 - The machine enters origin setup mode.
- 2** Press [▼] to advance the media to the cutting position.

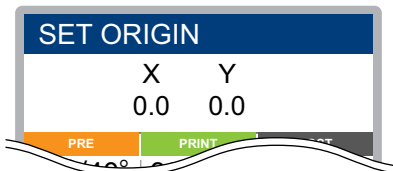

- 3** Select [CUT].
 - The media is now cut.
 - After cutting, the machine returns to local mode.

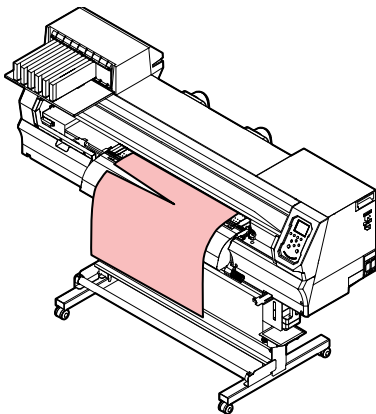

Chapter 3 Settings



About this chapter

This chapter describes various settings of the machine.

Setup Menu	3-2	Setting units (temperature/length)	3-9
Setup menu table	3-2	Registering and Correcting a Ink Cartridge	3-9
Registering optimal print conditions to match usage	3-3	Setting the key buzzer	3-10
Feed correction	3-3	Setting view feed	3-10
Dot position correction	3-3	Setting space feed mode	3-11
Heater	3-4	Setting the network	3-11
Logical seek	3-4	Setting the event mail function	3-12
Drying time	3-5	Initializing settings	3-15
Margin (left/right)	3-5	Nozzle Check Menu	3-16
Vacuum fan	3-5	Nozzle check menu table	3-16
Feed speed	3-5	Nozzle check flow during printing	3-17
MAPS	3-6	Printing operations when nozzle clogging is determined or errors occur	3-17
Auto cleaning	3-6	Setting nozzle checking during printing	3-18
Interval wiping	3-6	Setting auto nozzle recovery	3-18
Machine Setup Menu	3-7	Setting judgment conditions	3-18
Machine setup menu table	3-7	Information Menu	3-19
Setting auto power-off	3-9	Information menu table	3-19
Setting remaining media display	3-9	Displaying information	3-19
Setting the language	3-9		
Setting the time	3-9		

Setup Menu

From the setup menu, you can set the print conditions for media you normally use.

Setup menu table



- Each of the following setting items can be configured for operation according to setting values used during RIP printing from a connected host computer.
- **Setting items:** Drying time / Margin (left/right) / Vacuum / Feed speed level
- Set each item to "Host" for operation according to the RIP settings. To give priority to settings made on the machine, use a setting other than "Host."
- For instructions on setting up RIP software, refer to the RIP software instruction manual.

Function name		Setting value	Without RIP instructions *1	Description	
FEED COMP. (P.3-3)		-9999 to <u>0</u> to 9999		Used to print a pattern for correcting the media feed amount and then correcting it.	
DROP.POScorrect (P.3-3)		-40.0 to <u>0</u> to 40.0		Used to adjust the drop position in bidirectional printing.	
HEATER (P.3-4)	PRE	OFF / 20–50°C		Sets the temperature of each heater.	
	PRINT				
	POST				
	Off Time	0–90 min.		Sets the time until the heater is turned off after printing.	
LOGICAL SEEK (P.3-4)		HOST / ON / OFF	ON	Sets the scanning area during printing.	
DRYING TIME (P.3-5)	SCAN	HOST / 0.0–9.9 sec.	0 sec.	Sets the time to wait for ink to dry.	
	PRINT END	HOST / 0–120 min.	0 min.		
MARGIN / LEFT (P.3-5)		-10 to 85 mm	0 mm	Sets a non-printing area along the right and left edges of the media.	
MARGIN / RIGHT (P.3-5)			0 mm		
VACUUM (P.3-5)		HOST / WEAK / STANDARD / STRONG	STRONG	Sets the vacuum strength for the media.	
FEED SPEED *2 (P.3-5)		HOST / 10 to 200%	100%	Changes the media feed speed in printing and other tasks.	
AUTO CLEANING (P.3-6)	OFF, FILE, LENGTH, TIME			Sets operation of automatic head cleaning before or during printing. If there is a cartridge with [Ink Level Low] or [Ink Near End], printing is automatically interrupted during the cleaning run.	
	FILE	INTERVAL	1–1000		
		TYPE	NORMAL / SOFT / HARD		
	Length	INTERVAL	0.1–100.0 m		
		TYPE	NORMAL / SOFT / HARD		
	TIME	INTERVAL	120–480 min.		
TYPE		NORMAL / SOFT / HARD			
Cleaning Check		ON / OFF		Sets whether to check the nozzles after auto cleaning.	
INTERVAL WIPING (P.3-6)		3–255 min., OFF		Sets operation of wiping performed during printing.	
MAPS (P.3-6)	AUTO			Changes the effect of "MAPS."	
	MANUAL	Speed	50–100%		
		Smoothing Level	0–100%		
SETUP RESET (P.3-3)		Settings 1-4 can be reset individually.			

*1. Setting values used for printing when no setting value is indicated by the RIP software (host), or if you give priority to setting values configured on the machine.

*2. Set to 100% or more for faster printing, but note that sufficient drying time cannot be ensured, which may affect print quality.

Registering optimal print conditions to match usage

With this machine, you can register four separate print conditions (SETUP 1–4) to suit the media used.



- For example, after printing on a different type of media than usual, you can print on your usual media again simply by selecting the registered settings (1–4).

To print under conditions that you rarely use, select "Temporary" and set the print conditions.



- Temporary settings are restored to defaults (the state at the time of purchase) when the machine is turned off. SETUP1 is selected on startup if the machine is turned off with "Temporary" selected.
- You can also copy print conditions for SETUP 1–4 to "Temporary" and adjust them as needed before printing. Similarly, conditions set in "Temporary" can be copied to SETUP 1–4.

Registering print conditions in SETUP 1–4

1 With the screen in local mode, select [MENU] > [SETUP], and then press the [ENTER] key.

- SETUP options are displayed.

2 Select a SETUP option from 1 to 4 and press the [ENTER] key.

- The SETUP menu is displayed.

3 Select and set each setting item in the SETUP menu list.

- For details, see P.3-2 [Setup menu table].

Feed correction

You can correct the media feed amount by printing a correction pattern. Correct the media feed amount to suit the type of media you are using. Unsuitable correction values may result in banding or other printing problems.



- Roll media at the rear of the machine will not be taut after you perform feed correction and the media returns to the print origin. Manually rewind roll media before printing to keep it taut. Failure to observe these instructions may result in image quality problems.

1 Load the media.

- P.2-6 [Loading Media]

2 With the screen in local mode, select [MENU] > [SETUP], and then press the [ENTER] key.

- SETUP options are displayed.

3 Select a SETUP option from 1 to 4 and press the [ENTER] key.

- The SETUP menu is displayed.

4 Select [FEED COMP.], and then press the [ENTER] key.

5 Press the [ENTER] key to print the correction pattern.

6 Check the correction pattern.

- A screen for entering the correction value is displayed

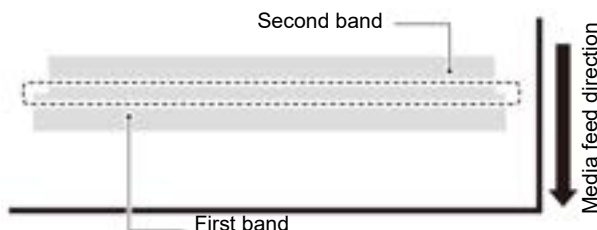

- Two bands are printed in the correction pattern. Adjust the feed amount so that the boundary between the bands has an even density.

7 Enter a correction value.

- **Entering positive correction values:**
Widens the boundary between bands.
- **Entering negative correction values:**
Narrows the boundary between bands.
- Changing the correction value by 30 adjusts the boundary width by about 0.1 mm.

8 Press the [ENTER] key.

- Print another correction pattern to check.

Dot position correction

Changing the media and print head height and temperature changes around the print head will also alter the drop positions. Correct the drop position to suit the type of media used. Image defects (e.g., overlaid lines or blurred images) will result if the drop position is not properly corrected.

1 Load the media.

- P.2-6 [Loading Media]
- Printing a pattern requires media at least 500 mm wide.

2 With the screen in local mode, select [MENU] > [SETUP], and then press the [ENTER] key.

- SETUP options are displayed.

3 Select a SETUP option from 1 to 4 and press the [ENTER] key.

- The SETUP menu is displayed.

4 Select [DROP.POScorrect] and press the [ENTER] key.

- The pattern for correcting the drop position is now printed.
- Multiple test patterns are printed, which are referred to by the order of printing.

5 Enter the correction resolution, and then press the [ENTER] key.

- Resolution : 720 / 1440 dpi
- The "Print Start Wait" screen appears.

6 Press the [ENTER] key in the [PRINT START] screen.

- Two patterns are printed per resolution.

7 Enter the correction value and press [ENTER].

- Enter the correction value for each resolution displayed in the pattern.
- Correction value: -40 to 40
- The position where the outward and return lines form a single straight line indicates the correction value to use.

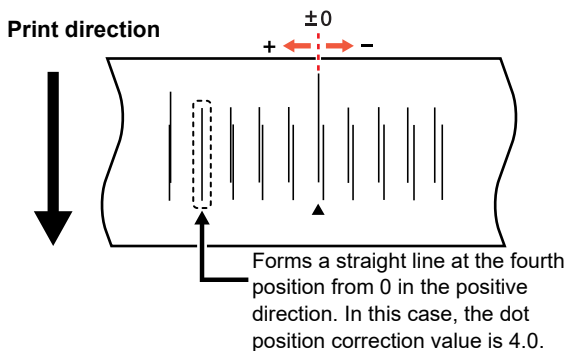

Heater

The platen incorporates a preheater, print heater, and post-heater.

Besides setting the temperature for each, you can set the time until the heater turns off after printing.

Type of heater	Function
Preheater	Preheats the media before printing to suppress rapid temperature change.
Print heater	Helps prevent ink bleeding.
Post-heater	Allows ink to dry after printing.

1 With the screen in local mode, select [MENU] > [SETUP], and then press the [ENTER] key.

- SETUP options are displayed.

2 Select a SETUP option from 1 to 4 and press the [ENTER] key.

- The SETUP menu is displayed.

3 Select [HEATER] and press the [ENTER] key.

4 Enter the heater temperatures, then press the [ENTER] key.

- **Heater selection:** Select with [▲]/[▼]
- **Temperature setting:** Set with [◀]/[▶]



- To give priority to RIP settings, use "Host" as the setting value.

5 Select [OFF TIME] and press the [ENTER] key.

6 Set the time until the heater turns off after printing and press the [ENTER] key.



- To fully deactivate heating, press [FUNC3] (OFF) in step 3. You can also increase all heating temperatures by 10°C by pressing [FUNC1].
- Heaters automatically return to the specified temperature if keys are pressed or data is received before the off-time set in step 6 elapses.

Logical seek

Modifies carriage operation during printing.

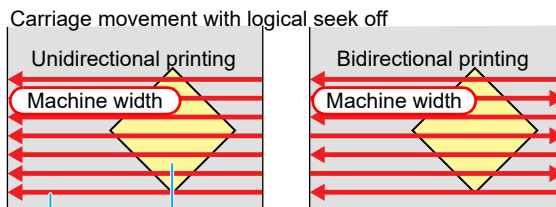

Print area

Red arrow: Carriage movement

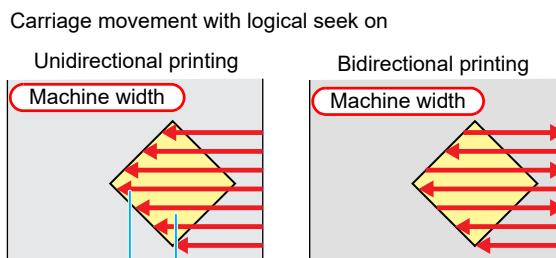

Print area

Red arrow: Carriage movement

1 With the screen in local mode, select [MENU] > [SETUP], and then press the [ENTER] key.

- SETUP options are displayed.

2 Select a SETUP option from 1 to 4 and press the [ENTER] key.

- The SETUP menu is displayed.

3 Select [LOGICAL SEEK] and press the [ENTER] key.

4 Select a setting value and press the [ENTER] key.

- Setting value: HOST / ON / OFF

Drying time

These setting items control ink drying time.

- **SCAN:** Set the ink drying time per scan. (In bidirectional printing, the machine pauses for the time set after each outward and return scan.)
- **PRINT END:** Set the ink drying time after printing is finished.



- "SCAN" as set on machine is identified as "Pause Time per Scan" in RasterLink.
- The print end setting cannot be set on the RasterLink side. Setting the machine setting to "Host" will print with "Print End=0 min."

1 With the screen in local mode, select [MENU] > [SETUP], and then press the [ENTER] key.

- SETUP options are displayed.

2 Select a SETUP option from 1 to 4 and press the [ENTER] key.

- The SETUP menu is displayed.

3 Select [DRYING TIME] and press the [ENTER] key.

4 Set each setting item, and then press the [ENTER] key.

- **Scanning setting value:** Host or 0.0–9.9 sec.
- **Print end setting value:** Host or 0–120 min.
- **Item selection:** Select with [▲]/[▼]
- **Time setting:** Set with [◀]/[▶]



- To give priority to RIP settings, use "Host" as the setting value.

Margin (left/right)

Set a non-printing area along the left and right edges of the media.

This is an offset value relative to the standard 15 mm margin.



- Margins cannot be set with the included RIP software (RasterLink). Setting the machine setting to "Host" when RasterLink is used will print with "Margins for right and left offset value=0 mm."
- The margin setting is applied when the media width is detected.

1 With the screen in local mode, select [MENU] > [SETUP], and then press the [ENTER] key.

- SETUP options are displayed.

2 Select a SETUP option from 1 to 4 and press the [ENTER] key.

- The SETUP menu is displayed.

3 Select [MARGIN / LEFT] or [MARGIN / RIGHT] and press the [ENTER] key.

4 Select a setting value and press the [ENTER] key.

- **Setting value:** HOST / -10 to 85 mm



- To give priority to RIP settings, use "Host" as the setting value.
- When the media holder is used in printing, setting the right and left margin to -5 mm or less may cause printing to start on the media holder.

Vacuum fan

Sets the force with which the medium is held down.

Setting suitable vacuum strength for the media can prevent print errors due to the media lifting up.

1 With the screen in local mode, select [MENU] > [SETUP], and then press the [ENTER] key.

- SETUP options are displayed.

2 Select a SETUP option from 1 to 4 and press the [ENTER] key.

- The SETUP menu is displayed.

3 Select [VACUUM] and press the [ENTER] key.

4 Select a setting value and press the [ENTER] key.

- **Setting value:** HOST / WEAK / STANDARD / STRONG

Feed speed

Changes the media feed speed in printing and other tasks.

1 With the screen in local mode, select [MENU] > [SETUP], and then press the [ENTER] key.

- SETUP options are displayed.

2 Select a SETUP option from 1 to 4 and press the [ENTER] key.

- The SETUP menu is displayed.

3 Select [FEED SPEED] and press the [ENTER] key.

4 Select a setting value and press the [ENTER] key.

- **Setting value:** HOST / 10–200%



- To give priority to RIP settings, use "Host" as the setting value.
- Depending on print conditions, the speed may not vary for certain settings.

MAPS

MAPS (Mimaki Advanced Pass System) evens out ink ejection at pass boundaries to reduce banding between passes. This function enables you to change the extent to which MAPS is applied.



- MAPS provides two setting options: "AUTO" and "MANUAL." Because processing most suitable for the printing conditions is applied with MAPS, normally use the default option of "AUTO."
- This function requires Mimaki driver Ver. 4.2.0 or higher.



- Changing the MAPS settings may change the color tone. Check the results before use.
- MAPS may not be effective when printing certain images. Check the results before use.

Auto cleaning

Can be set so that cleaning is performed automatically after a set number of files, media length, or time to date. This enables consistent printing, with heads kept clean.

Three auto cleaning options are available, as follows.

FILE	Auto cleaning is performed after the specified print volume.
LENGTH	Auto cleaning is performed after the machine has fed the specified length of media.
TIME	Auto cleaning is performed after the specified time has elapsed.

Automatic nozzle checking (Cleaning Check) after auto cleaning can also be set.



- If there is a cartridge with [Ink Level Low] or [Ink Near End], printing is automatically interrupted during the cleaning run.

1 With the screen in local mode, select [MENU] > [SETUP], and then press the [ENTER] key.

- SETUP options are displayed.

2 Select a SETUP option from 1 to 4 and press the [ENTER] key.

- The SETUP menu is displayed.

3 Select [AUTO CLEANING] and press the [ENTER] key.

4 Select a setting value and press the [ENTER] key.

- Setting value: FILE / LENGTH / TIME / OFF

5 Select a setting value and press the [ENTER] key.

- Setting values vary depending on your selection in the previous step.
- For FILE: 1–1000 files
- For LENGTH: 0.1–100.0 m (in 0.1 m increments)
- For TIME: 10–480 min. (in 10 min. increments)

6 Select [TYPE] and press the [ENTER] key.

- Select the type of cleaning and press the [ENTER] key.
- Setting value: NORMAL / SOFT / HARD

7 Select [Cleaning Check] and press the [ENTER] key.

8 Select a setting value and press the [ENTER] key.

- Setting value: ON / OFF



- Depending on the state of heads and other factors, this function may not be able to restore print quality that has declined. In this case, contact your dealer, service office, or call center.

Interval wiping

After the specified amount of time has elapsed, the head nozzle surface is automatically cleaned to remove ink droplets adhering to the nozzle surface.

Set an interval in case of nozzle clogging, deflection, falling ink droplets, or similar symptoms.

1 With the screen in local mode, select [MENU] > [SETUP], and then press the [ENTER] key.

- SETUP options are displayed.

2 Select a SETUP option from 1 to 4 and press the [ENTER] key.

- The SETUP menu is displayed.

3 Select [INTERVAL WIPING] and press the [ENTER] key.

4 Select a setting value and press the [ENTER] key.

- Setting value: 3–255 min. / OFF

Machine Setup Menu

The Machine Setup menu provides a variety of convenient settings.

The following items can be set in the machine settings.

Machine setup menu table

Function name		Setting value	Default Setting	Details
AUTO Power-off (P.3-9)		5–60 min.	5 min.	Automatically turns off the machine after it has been left idle for the specified time.
Top blower		ON / OFF	OFF	Set the operation of the top blower in print.
MEDIA REMAIN (P.3-9)		ON / OFF	OFF	Enables management of the remaining amount of media.
LANGUAGE (P.3-9)			English	Changes the display language.
TIME SET (P.3-9)		+4 h to -20 hr.	Japan time	Sets the current time and date.
UNIT / TEMP (P.3-9)		°C (Celsius) / °F (Fahrenheit)	°C	Sets the unit for temperature display.
UNIT / LENGTH (P.3-9)		mm / inch	mm	Sets the unit for length and area display.
Eco cartridge	Case Weight	_____		Registers the eco cartridge case weight.
	Cartridge Weight	_____		Registers the cartridge weight.
KEY BUZZER (P.3-10)		ON / OFF	ON	Sets an audible tone when keys are pressed.
VIEW FEED (P.3-10)		ON / OFF	ON	Sets whether media feeding is performed in order to check test printing results, for example.
SPACE FEED MODE (P.3-10)		INTERMITTENT / CONTINUOUS	INTERMITTENT	Alters the feed method for blank space included in image data.
Network (P.3-11)	For configuring network settings.			
	Check IP ADDRESS	Shows the machine's current IP address.		
	Check MAC ADDRESS	Shows the machine's current MAC address.		
	DHCP	ON / OFF		Set to ON to use an IP address set by the DHCP server.
	AutoIP	ON / OFF		Set to ON to use an IP address set by the AutoIP protocol. Note that DHCP is given priority when DHCP is set to ON.
	IP ADDRESS* ¹	Sets the IP address used by the machine.		
	DEFAULT GATEWAY* ¹	Sets the default gateway used by the machine.		
	DNS ADDRESS* ¹	Sets the DNS server address used by the machine.		
	SUB NET MASK* ¹	Sets the subnet mask used by the machine.		

Function name		Setting value		Default Setting	Details
EVENT MAIL	TRANSMIT TEST (☞ P.3-12)	ON / OFF		OFF	Sets whether to send email when a specified event occurs.
	SELECT EVENT SELECT (☞ P.3-12)	PRINT START	ON / OFF	OFF	Sets whether to send email when printing starts.
		PRINT END	ON / OFF	OFF	Sets whether to send email when printing ends.
		ERROR EVENT	ON / OFF	OFF	Sets whether to send email when errors occur.
		WARNING EVENT	ON / OFF	OFF	Sets whether to send email when warnings occur.
		OTHER EVENT	ON / OFF	OFF	Sets whether to send email when events other than the above occur.
	MAIL ADDRESS (☞ P.3-12)	Sets the recipient email address for event mail.		Alphanumeric characters and symbols (up to 96 characters)	
MESSAGE SUBJECT (☞ P.3-12)	Sets the text for the subject of event mail.		Alphanumeric characters and symbols (up to 8 characters)		
EVENT MAIL	SERVER SETUP (☞ P.3-12)	SMTP ADDRESS		Sets the SMTP server.	
		SMTP PORT No.		Sets the SMTP port number.	
		SENDER MAIL ADDRESS		Sets the sender email address.	
		Authentication	OFF	Sets the method of SMTP server authentication.	
			POP before SMTP		
			SMTP Authentication		
		USER NAME *2		Sets the user name for authentication.	
		PASS WORD *2		Sets the password for authentication.	
	POP3 ADDRESS *3		Sets the POP server address.		
APOP *3		Sets APOP on or off.			
TRANSMIT TEST (☞ P.3-13)	Sends a test email.				
Auto Remote		ON / OFF		Sets whether to automatically switch to REMOTE mode and start printing if data is received locally.	
Circulation Lv.		AUTO / OFF / Lv.1 / Lv.2		AUTO	<p>Changes the setting for the circulation operation while printing.</p> <p>(☞ P.4-22 「Recovering from frequent nozzle dropout and nozzle ejection failures of white」)</p> <p><u>Blinking Keyboard LED</u></p> <p>It blinks momentarily when it is time to return from the menu to the local screen.</p> <ul style="list-style-type: none"> • In case of operation equivalent to OFF No blinking • Blinks once when the operation is equivalent to Lv1 • Blinks twice when operating at or equivalent to Lv2
RESET (☞ P.3-15)				Restores the default values of all setting items.	

*1. Available when both DHCP and AutoIP are set to OFF.

*2. Available only when Authentication is not OFF.

*3. Available only when Authentication is POP before SMTP.

Setting auto power-off

Automatically turns off the machine after it has been left idle for the specified time.

1 With the screen in local mode, select [MENU] > [MACHINE SETUP], and then press the [ENTER] key.

- The MACHINE SETUP menu is displayed.

2 Select [AUTO Power-off] and press the [ENTER] key.

3 Select a setting value and press the [ENTER] key.

- Setting value :5–60 min.

Setting remaining media display

Set whether the remaining amount of media is displayed.

With MEDIA REMAIN set to ON	The remaining amount of media is displayed in remote mode.
With MEDIA REMAIN set to OFF	The remaining amount of media is not displayed in remote mode.



- The amount of media left is determined by the amount of media fed both by printing and by using the jog keys.
- Media length (equivalent to the initial value of the amount remaining) is entered when roll media is detected (P.2-9 [Entering the remaining amount of media]).
- Takes effect when media is detected after this setting is made.

1 With the screen in local mode, select [MENU] > [MACHINE SETUP], and then press the [ENTER] key.

- The MACHINE SETUP menu is displayed.

2 Select [MEDIA REMAIN] and press the [ENTER] key.

3 Select a setting value and press the [ENTER] key.

- Setting value: ON / OFF



- With MEDIA REMAIN set to ON, you can print a list of current media remaining and the date (P.2-9 [Printing information about the remaining amount of media]).

Setting the language

Changes the display language.

1 With the screen in local mode, select [MENU] > [MACHINE SETUP], and then press the [ENTER] key.

- The MACHINE SETUP menu is displayed.

2 Select [LANGUAGE] and press the [ENTER] key.

3 Select a language and press the [ENTER] key.

Setting the time

You can set the time (time difference) in the country of use.

1 With the screen in local mode, select [MENU] > [MACHINE SETUP], and then press the [ENTER] key.

- The MACHINE SETUP menu is displayed.

2 Select [TIME] and press the [ENTER] key.

3 Select a setting value and press the [ENTER] key.

- Time selection: Select with [◀]/[▶] keys
- Time input: Set with [▲]/[▼] keys



- Can be set in a range of -20 to +4 hours.

Setting units (temperature/length)

Set the units used by the machine.

1 With the screen in local mode, select [MENU] > [MACHINE SETUP], and then press the [ENTER] key.

- The MACHINE SETUP menu is displayed.

2 Select [UNIT / TEMP] or [UNIT / LENGTH] and press the [ENTER] key.

3 Select a setting value and press the [ENTER] key.

- Temperature setting value: °C/°F
- Length setting: mm/inch

Registering and Correcting a Ink Cartridge

Required Items

Eco-case	The ink pack and the ink IC chip provided with the ink pack are placed in the eco ink cartridge case.
Ink pack	
Ink IC chip	
Scale	The weight of the cartridge is registered to calculate the amount of remaining ink. Use a scale capable of weighing in 1 g increments.

Replacing with a New Ink Cartridge

Register the eco ink cartridge case weight.



- Do not perform registration if not replacing the eco ink cartridge with a new one.

1 Weigh the eco ink cartridge case.

- Do not install the ink pack and the ink IC chip at the stage.

2 Place the ink pack and the ink IC chip in the eco ink cartridge case.

- (☞ P.1-14 「Replacing Ink」)

3 Insert the eco ink cartridge in the ink supply unit.**4 In LOCAL mode screen, select [MENU] > [Machine Setup], then press the [ENTER] key.**

- The Machine Setup menu is displayed.

5 Select [Eco cartridge] > [Case Weight], then press the [ENTER] key.**6 Select the required ink slot, then press the [ENTER] key.**

- The selected slot is highlighted.

7 Enter the measured weight of the eco ink cartridge case, then press the [ENTER] key.

- Check the following when "ERROR614 Preservation Failure" appears:
 - (1) Check to confirm that the eco ink cartridge was fully inserted.
 - (2) Check to confirm the ink IC chip was installed correctly.

Correcting the Ink Cartridge Case Weight

When the remaining ink level in the eco ink cartridge reaches a preset level, [Ink Level Low], [Ink Near End], [Ink Level End], or [Ink End] appears on the display. The weight may differ from the actual weight, so the weight of the eco ink cartridge should be corrected.



- If non-actual weights are registered repeatedly, the ink IC chip can no longer be used.
- Continuous printing is not possible when the warning is displayed.
- Replace with a new ink pack when "Replace Ink-pack" is displayed.

1 A warning appears on the display.**2 Remove the eco ink cartridge case in the indicated ink slot, and measure the weight.**

- Weight with the ink pack inserted.

**3 Insert the eco ink cartridge in the ink supply unit.**

- The cartridge weight screen appears.

4 Enter the measured weight of the eco ink cartridge, then press the [ENTER] key.

- The remaining ink amount of the ink pack is calculated and saved in the ink IC chip.
- The weight of the eco cartridge can be registered as follows:
 - (1) In LOCAL mode screen, select [MENU] > [Machine Setup], then press the [ENTER] key.
 - The Machine Setup menu is displayed.
 - (2) Select [Eco cartridge] > [Cartridge Weight], then press the [ENTER] key.
 - (3) (3) Select the required ink slot, then press the [ENTER] key.
 - The selected slot is highlighted.
 - (4) Enter the measured weight of the eco ink cartridge, then press the [ENTER] key.



- Check the following when "ERROR614 Preservation Failure" appears:
 - (1) Check to confirm that the eco ink cartridge was fully inserted.
 - (2) Check to confirm the ink IC chip was installed correctly.

Setting the key buzzer

You can turn off the buzzer sound that is played when keys are pressed.

1 With the screen in local mode, select [MENU] > [MACHINE SETUP], and then press the [ENTER] key.

- The MACHINE SETUP menu is displayed.

2 Select [KEY BUZZER] and press the [ENTER] key.**3 Select a setting value and press the [ENTER] key.**

- Setting value: ON / OFF



- Setting the buzzer to OFF does not disable sounds for errors, warnings, or completion of operation.

Setting view feed

Sets whether media feeding is performed in order to check test printing results, for example.

1 With the screen in local mode, select [MENU] > [MACHINE SETUP], and then press the [ENTER] key.

- The MACHINE SETUP menu is displayed.

2 Select [VIEW FEED] and press the [ENTER] key.**3 Select a setting value and press the [ENTER] key.**

- Setting value: ON / OFF

Setting space feed mode

Alters the feed method for blank space included in image data if there is no data to print. Data with wide margins can be printed in less time when set to [CONTINUOUS].

- 1** With the screen in local mode, select [MENU] > [MACHINE SETUP], and then press the [ENTER] key.
 - The MACHINE SETUP menu is displayed.
- 2** Select [SPACE FEED MODE] and press the [ENTER] key.
- 3** Select a setting value and press the [ENTER] key.
 - **INTERMITTENT:** Feeds intermittently based on a fraction of a printing pass.
 - **CONTINUOUS:** Feeds by skipping blank parts all at once.

Setting the network

- 1** With the screen in local mode, select [MENU] > [MACHINE SETUP], and then press the [ENTER] key.
 - The MACHINE SETUP menu is displayed.
 - 2** Select [NETWORK] > [Check IP ADDRESS], and then press the [ENTER] key.
 - The machine's current IP address is displayed.
 - After you have checked it, press the [ENTER] key.
-  It takes some time after a network connection is established until the IP address is determined. "0.0.0.0" is displayed when the IP address has not been determined yet.
- 3** Select [Check MAC ADDRESS] and press the [ENTER] key.
 - The machine's current MAC address is displayed.
 - After you have checked it, press the [ENTER] key.
 - 4** Select [DHCP] and press the [ENTER] key.
 - 5** Select a setting value and press the [ENTER] key.
 - **Setting value:** ON / OFF
 - Set to ON to use an IP address set by the DHCP server.
 - 6** Select [AutoIP] and press the [ENTER] key.
 - 7** Select a setting value and press the [ENTER] key.
 - **Setting value:** ON / OFF
 - Set to ON to use an IP address set by the AutoIP protocol. Note that DHCP is given priority when DHCP is set to ON.

- 8** Select [IP ADDRESS] and press the [ENTER] key.

- 9** Select a setting value and press the [ENTER] key.
 - **Setting value:** ON / OFF
 - You can set an IP address when both DHCP and AutoIP are set to OFF. In other cases, go to step 14.

- 10** Press the  key.
 - Setting items for the default gateway, DNS address, and subnet mask are displayed.
 - You can set the default gateway, DNS address, and subnet mask when both DHCP and AutoIP are set to OFF. In other cases, go to step 12.

- 11** Select a setting item and press the [ENTER] key.

- 12** Select a setting value and press the [ENTER] key.



- Restart the machine to apply network settings.

Setting the event mail function

Configure this function to send an email to your specified address after events such as printing starting/ending or interruption due to errors.

- Disclaimer
- You will bear any costs for email notification or other internet communication.
- Notifications from the event mail function may not be delivered due to the internet environment, equipment failure, power failure, or other factors. Mimaki is not liable for any damages or loss caused by non-delivery or delays.



- The event mail function is available when the machine is connected to the internet via LAN. Connect the LAN cable in advance.
- Not compatible with SSL communication.

Enabling event mail

- 1 With the screen in local mode, select [MENU] > [MACHINE SETUP], and then press the [ENTER] key.
 - The MACHINE SETUP menu is displayed.
- 2 Select [EVENT MAIL] > [MAIL DELIVERY], and then press the [ENTER] key.
- 3 Select [ON] and press the [ENTER] key.

Setting events that trigger event mail

- 1 With the screen in local mode, select [MENU] > [MACHINE SETUP], and then press the [ENTER] key.
 - The MACHINE SETUP menu is displayed.
- 2 Select [EVENT MAIL] > [SELECT EVENT], and then press the [ENTER] key.
- 3 Select an event and press [FUNC2] (✓).
 - After selecting an event, press [FUNC2] to select a check box. An email will be sent if the selected event occurs.
 - To select multiple events, press [▲]/[▼] to move the cursor to events to select and press [FUNC2] to select the check boxes.

Event name	Description
PRINT START	Sets whether to send email when printing starts.
PRINT END	Sets whether to send email when printing ends.
ERROR EVENT	Sets whether to send email when errors occur that interrupt printing.
WARNING EVENT	Sets whether to send email when warnings occur during printing.
OTHER EVENT	Sets whether to send email when events other than the above occur.

Setting the email address

- 1 With the screen in local mode, select [MENU] > [MACHINE SETUP], and then press the [ENTER] key.
 - The MACHINE SETUP menu is displayed.
- 2 Select [EVENT MAIL] > [MAIL ADDRESS], and then press the [ENTER] key.
- 3 Specify the address and press the [ENTER] key.
 - Sets the recipient email address for event mail.
 - Use alphanumeric characters and symbols (up to 96 characters).

Setting the subject

- 1 With the screen in local mode, select [MENU] > [MACHINE SETUP], and then press the [ENTER] key.
 - The MACHINE SETUP menu is displayed.
- 2 Select [EVENT MAIL] > [MESSAGE SUBJECT], and then press the [ENTER] key.
- 3 Specify the subject and press the [ENTER] key.
 - Sets the text for the subject of event mail.
 - Use alphanumeric characters and symbols (up to 8 characters).

Setting the server

- 1 With the screen in local mode, select [MENU] > [MACHINE SETUP], and then press the [ENTER] key.
 - The MACHINE SETUP menu is displayed.
- 2 Select [EVENT MAIL] > [SERVER SETUP] > [SMTP ADDRESS], and then press the [ENTER] key.
- 3 Specify the SMTP address and press the [ENTER] key.
 - Press [▲]/[▼] / [◀]/[▶] to set the SMTP address.
 - Enter the SMTP address name.
- 4 Select [SMTP PORT No.] and press the [ENTER] key.
- 5 Specify the SMTP port number and press the [ENTER] key.
 - Sets the SMTP port number.
- 6 Select [SENDER MAIL ADDRESS] and press the [ENTER] key.
- 7 Select the sender mail address and press the [ENTER] key.
 - Press [▲]/[▼] / [◀]/[▶] to specify the address to use as the sender's address.

- Use alphanumeric characters and symbols (up to 64 characters).



- Depending on the server used, the machine may not be able to send emails unless you set up an email address corresponding to your account.

8 Select [Authentication] and press the [ENTER] key.

9 Specify the method of authentication and press the [ENTER] key.

- Sets the method of SMTP server authentication.
- If you have selected OFF, go to step 17.

10 Select [USER NAME] and press the [ENTER] key.

11 Specify the user name and press the [ENTER] key.

- Press [▲]/[▼]/[◀]/[▶] to set the user name used for authentication.
- Use alphanumeric characters and symbols (up to 30 characters).

12 Select [PASS WORD] and press the [ENTER] key.

13 Specify the password and press the [ENTER] key.

- Press [▲]/[▼]/[◀]/[▶] to set the password used for authentication.
- Use alphanumeric characters and symbols (up to 15 characters).



- The password setting screen only allows you to check the value you are currently entering.
- If you have selected [POP before SMTP], set the items in step 13–16.

14 Select [POP3 Address] and press the [ENTER] key.

15 Specify the POP3 address and press the [ENTER] key.

- Press [▲]/[▼]/[◀]/[▶] to set the POP server. Enter the POP server name.

16 Select [APOP] and press the [ENTER] key.

17 Select a setting value and press the [ENTER] key.

- Setting value: ON / OFF

Sending test email

1 With the screen in local mode, select [MENU] > [MACHINE SETUP], and then press the [ENTER] key.

- The MACHINE SETUP menu is displayed.

2 Select [EVENT MAIL] > [TRANSMIT TEST], and then press the [ENTER] key.

3 Press the [ENTER] key.

- Results of transmission are displayed.
- If testing email transmission fails, an error code is displayed.

Transmit Test
Failed: 12345: ent

Error code



- Results of testing email transmission represents the result of transmission as performed by the machine to the mail server. It does not indicate that email was received at the address.
- If the recipient has set up a spam filter or the like, email may not reach them even if the machine indicates that it has been sent.
- If testing email transmission fails, the following error codes are displayed.
- If the error cannot be resolved, wait a while and try again.
- For server settings and similar information, contact your network administrator or the provider.

Error code

Error code	Possible cause	Corrective action
10	Network connection error	<ul style="list-style-type: none"> • Confirm that the machine is connected to the network. • Confirm that the machine IP address is correct. • Confirm that the machine is used in an environment where DNS is available.
20	No valid email address.	<ul style="list-style-type: none"> • Enter the correct email address.
11003 11004	The POP server cannot be found. Otherwise, the DNS server cannot be accessed.	<ul style="list-style-type: none"> • Check the POP server address. • Confirm that the machine is used in an environment where DNS is available.
11021	Cannot connect to the POP server.	<ul style="list-style-type: none"> • Check the POP server settings. • Check the firewall settings.
12010	An error was returned from the POP server.	<ul style="list-style-type: none"> • Check the POP server settings.
13000	POP authentication failed.	<ul style="list-style-type: none"> • Check the user name and password. • Check the APOP settings. • Check the authentication method.
10013 10014	The SMTP server cannot be found. Otherwise, the DNS server cannot be accessed.	<ul style="list-style-type: none"> • Check the SMTP server address. • Confirm that the machine is used in an environment where DNS is available.
10021	Cannot connect to the SMTP server.	<ul style="list-style-type: none"> • Check the SMTP server settings. • Check the SMTP port number. • Check the firewall settings.
10*** 11*** 20*** 21***	An error was returned from the SMTP server. Otherwise, there was no response.	<ul style="list-style-type: none"> • Check the SMTP server settings. • The machine cannot communicate with servers that require SSL communication. • Check protocol filter settings.
12***	Invalid sender address.	<ul style="list-style-type: none"> • Confirm that the email address for the account with the user name and password you entered is set as the sender mail address.
13***	The email address cannot be found. Otherwise, it is an invalid address.	<ul style="list-style-type: none"> • Check the email address. • This error may not be detected in some cases, even if the email address is incorrect. • Confirm that the email address for the account with the user name and password you entered is set as the sender mail address.
22000 22008	SMTP authentication error	<ul style="list-style-type: none"> • Check the authentication method.
23*** 24*** 25***	SMTP authentication failed.	<ul style="list-style-type: none"> • Check the user name and password.

Initializing settings

Resets setting values to the state at the time of purchase.

- 1** With the screen in local mode, select [MENU] > [MACHINE SETUP], and then press the [ENTER] key.
 - The MACHINE SETUP menu is displayed.
- 2** Select [RESET] and press the [ENTER] key.
- 3** Press the [ENTER] key.
 - The settings are now initialized.

Nozzle Check Menu

Used to set nozzle clogging detection.

Nozzle check menu table

Function name		Setting value	Default	Description	
Nozzle checking during printing (☞ P.3-18)		ON/OFF	OFF	Set to check nozzles when the printer is online and about to begin printing.	
(ON)	Check Interval	LENGTH	0.1–50.0 m	30.0 m	Checks nozzles each time the specified length of media is used. *1
		FILE	1–100 files	30 files	Checks nozzles each time the specified number of files is printed.
	Action	CLEANING	SOFT/ NORMAL/ HARD	SOFT	Sets the type of cleaning.
		RETRY COUNT	0–3	0	Retries the specified number of times.
AUTO NOZZLE RECOVERY (☞ P.3-18)		ON/OFF	OFF	Set for automatic nozzle recovery.	
Judgment Condition (☞ P.3-18)		1–180 nozzles	1 nozzle	Sets the number of clogged nozzles detected in each color that determines nozzle clogging (up to 16 nozzles per row). *2	

*1. When the set length is reached during printing, nozzles are checked the next time printing begins.

*2. Depending on printing conditions, nozzle recovery may not apply in some cases.

Nozzle check flow during printing

Nozzles are checked in the following sequence when printing begins.



- To enable, set [Printing Check] to ON.
- Retry and auto nozzle recovery are available when this setting is enabled.

1 Nozzle check → Judgment

Nozzle clogging are detected.

2 Nozzle recovery → Nozzle check → Judgment

If checking indicates that the number of clogged nozzles exceeds the [Judgment Condition] setting, the nozzles are cleaned and rechecked.

3 Retry → Judgment

If more clogged nozzles than set in [Judgment Condition] are detected after nozzle recovery, recovery is repeated.

- To enable, set [RETRY COUNT] to 1 or more.

4 Auto nozzle recovery → Judgment

Nozzle recovery is automatically performed after nozzle checking and recovery operations.

- To enable, set [AUTO NOZZLE RECOVERY] to ON.

5 Nozzle clogging detection

If the last step indicates more clogged nozzles than set in [Judgment Condition], the machine determines that printing cannot be continued and stops printing.

Printing operations when nozzle clogging is determined or errors occur

- **Nozzle clogging is determined** → Printing is stopped.
- **Errors during nozzle checking** → Printing is stopped and [Printing Check] is automatically turned OFF. After error recovery, set up [Printing Check] again.

Setting nozzle checking during printing

Set to ON to check nozzles when the printer is online and about to begin printing.

- 1** With the screen in local mode, select [MENU] > [NOZZLE CHECK], and then press the [ENTER] key.
 - The nozzle check menu is displayed.
- 2** Select [Printing Check] > [ON], and then press the [ENTER] key.
 - To disable this nozzle checking, select [OFF].
- 3** Select [Check Interval] and press the [ENTER] key.
- 4** Select a setting item and press the [ENTER] key.
 - **LENGTH:** Checks nozzles after the machine has fed the specified length of media.
 - **FILE:** Checks nozzles after the number of files printed reaches the specified value.
- 5** Select a setting value and press the [ENTER] key.
 - Setting values vary depending on whether you have selected [Length] or [File] above.
 - **LENGTH:** 0.1–50 m
 - **FILE:** 1–100 files
- 6** Select [Action] > [CLEANING], and then press the [ENTER] key.
- 7** Select the type of cleaning, and then press the [ENTER] key.
 - **Setting value:** SOFT / NORMAL / HARD
- 8** Select [Action] > [RETRY COUNT], and then press the [ENTER] key.
 - **Setting value:** 0–3 times

Setting auto nozzle recovery

Set to perform automatic nozzle recovery if nozzle clogging is detected.

- 1** With the screen in local mode, select [MENU] > [NOZZLE CHECK], and then press the [ENTER] key.
 - The nozzle check menu is displayed.
- 2** Select [AUTO NOZZLE RECOVERY] and press the [ENTER] key.
- 3** Select a setting value and press the [ENTER] key.
 - **Setting value:** ON / OFF

Setting judgment conditions

Set the conditions that determine nozzle clogging.

- 1** With the screen in local mode, select [MENU] > [NOZZLE CHECK], and then press the [ENTER] key.
 - The nozzle check menu is displayed.
- 2** Select [Judgment Condition] and press the [ENTER] key.
- 3** Press the [ENTER] key to select a color.
- 4** Select the number of nozzles that determines the judgment, and then press the [ENTER] key.

Information Menu

Enables you to check information about the machine. You can check the following items of machine information.

Information menu table

Item		Details
USAGE	WIPING	Indicates the wiping count.
	WASTE TANK	Indicates the waste ink level (as a percentage of the tank capacity) as a guideline.
	PRINT LENGTH	Indicates the total length of media printed to date.
	PRINT AREA	Indicates the total area of media printed to date.
	USE TIME	Indicates the total machine usage time to date.
	PinchRollers use PrintLength	Displays the length printed with the pinch roller currently in use. It is reset when [Maintenance] > [Pinch Roller Replacement] is executed at the time of replacement.
VERSION		Indicates machine version information.
LIST		Can be used to print a list of machine settings.
ERROR HISTORY		Shows a record of errors and warnings to date. Pressing [▲]/[▼] switches between display of the date of occurrence (year/month/day/hour/minute) and the error/warning information, in order of occurrence.

Displaying information

1

With the screen in local mode, select [MENU] > [INFORMATION], and then press the [ENTER] key.

- The information menu is displayed.

2

Select your preferred information and press the [ENTER] key.

- See P.3-19 [Information menu table] and select the information to display.
- To print machine settings details, select [LIST] in step 2.



- To reset the wiper usage count, press the [FUNC2] key while "Clear?" is displayed. Press the [ENTER] key to reset the wiping count.
- You can reset the usage count by pressing function keys while [WIPING], [WASTE TANK], or [Spout Rubber] information is displayed:
 - **Resetting WIPING usage count:** [FUNC2]
 - **Resetting WASTE TANK usage count:** [FUNC1]

Chapter 4 Maintenance



About this chapter

This chapter describes the essentials for keeping the machine operating smoothly, such as routine care, and ink cartridge maintenance.

Performing Maintenance	4-3	Auto Maintenance Functions	4-14
Maintenance items and timing	4-3	Filling with ink	4-15
Tools required for maintenance	4-3	Replacing Consumables	4-16
Routine Maintenance	4-4	Replacing wipers	4-16
Ink maintenance	4-4	Replacing exhaust box filters	4-16
Cleaning the wiper and cap	4-4	Replacing the CP pad set	4-17
Cleaning the wiper cleaner	4-5	Replacing pinch rollers	4-17
Cleaning the wiper ink guard	4-5	Replacing fan filters	4-18
Cleaning under the carriage	4-5	Replacing cutter blades	4-18
NCU Cleaning	4-7	Waste Ink Tank	4-19
Cleaning the waste ink draining channel	4-7	In case of messages to check	
Cleaning head nozzles	4-8	waste ink	4-19
Preparing the machine if it will not be used over extended periods	4-9	Examples of Printing Issues	4-21
Cleaning media sensors	4-10	Recovering from nozzle ejection failure	4-22
Cleaning media holders	4-10	Recovering from frequent nozzle dropout and nozzle ejection failures of white	4-22
Cleaning the platen	4-10		
Cleaning exterior surfaces	4-11		
Cleaning jam sensors	4-11		
Maintenance Functions	4-12		
Nozzle recovery function	4-13		

Maintenance Precautions



- This machine includes parts that must be replaced periodically. We therefore recommend taking out a maintenance contract. Carry out maintenance periodically and replace consumable items to prevent quality defects and accidents.



- Clean periodically. Debris and dust will accumulate on electrical components when the machine is used for extended periods. There is a risk of failure, electric shock, or fire due to current leakage.
- Do not clean by blowing—e.g., avoid using air blowers. Doing so may lead to failure, electric shock, or fire involving the machine if airborne debris or dust gets inside electrical components. Wipe using a soft cloth soaked in diluted neutral detergent and thoroughly wrung out. A vacuum cleaner may also be used for cleaning.



- Do not allow liquids to get inside the machine. Otherwise there is a risk of failure, electric shock, or fire.



- For heavy soiling, wipe using a soft cloth soaked in diluted neutral detergent and thoroughly wrung out.



- Pay close attention to ventilation and be sure to wear safety glasses, gloves, and a mask when handling ink, maintenance liquid, waste ink, or other solutions used with the machine. Leaking ink may adhere to the skin or get into the eyes or mouth.



- Never touch the print head nozzle surface. Do not allow water or alcohol to come into contact with the print nozzle surface. This will increase the risk of machine failure or ejection failures (e.g., nozzle clogging or deflection).
- Do not use cotton swabs to clean around the head or carriage. Fibers from cotton swabs may adhere to the head nozzle surface and lead to ejection failures (e.g., nozzle clogging or deflection).
- Do not splash ink or maintenance liquid on the covers. Exposure to splashing ink or maintenance liquid may damage or deform the cover.
- Do not use benzine, thinner, or any chemical agent containing abrasives. Use of these chemicals may result in damage to or deformation of parts.
- Do not move the carriage by hand. To move the carriage, use the carriage out function on the menu.

Performing Maintenance

Maintenance should be performed regularly or based on how often the machine is used, in order to maintain printing accuracy and ensure long-term use.

This is a precision machine with extremely delicate mechanisms. In particular, the head nozzle surface from which ink is discharged may be affected by even the slightest amount of adhering dust or paper dust, which may prevent achieving optimal printing results.

To keep the machine operating in good condition, we recommend the following routine maintenance.

Maintenance items and timing

Timing	Item
Daily after work	Cleaning the wiper and cap
	Cleaning the wiper cleaner
	Cleaning the wiper ink guard
	Cleaning under the carriage
	Cleaning media sensors
	Cleaning media holders
	Cleaning jam sensors
Weekly after work	Cleaning the platen
	Cleaning exterior surfaces
	Waste Ink Tank
	Cleaning the waste ink draining channel
Weekly before work	Ink maintenance
When not used for more than a week	Preparing the machine if it will not be used over extended periods
When soiled, replace or clean	Replacing exhaust box filters
	Replacing the CP pad set
	Replacing pinch rollers

Tools required for maintenance

To order replacement consumable items, contact your local dealer or our service office. For more information on consumable items, refer to our website (<https://mimaki.com/supply/inkjet.html>).



- Avoid storing this product in locations accessible to children.



- Use the maintenance liquid designed for the machine.

Routine Maintenance

Ink maintenance

Shake the ink regularly before use. Failure to shake the ink regularly may result in ink sedimentation and reduced print quality. How often to shake the ink varies depending on the type and color.

Ink should be shaken as often as described below. For instructions on shaking ink, see "Inserting Ink Cartridges."

White ink:40 times

- After the machine has been on for 24 hours
- If "Shake white cartridge" is displayed as a warning message after the machine is turned on

Other colors:20 times

- Once a week, always before work

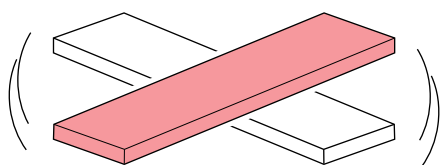

- White ink should be shaken 100 times after more than 3 days.



- Do not remove the ink cartridge when the display shows "CIRCULATION" or the LED is flashing.

Cleaning the wiper and cap

Using a dirty wiper with dried ink or dust on it may cause the wiper to rub against the nozzle surface or cause ink suction problems that lead to ejection failure (such as nozzle clogging or deflection).



- **Wiper:** Wipes off ink adhering to the print head nozzle surface.
- **Cap:** Prevents the print head nozzle surface from drying out.



- Replace wipers with a new one if they become deformed, or if adhering ink cannot be wiped away. Also replace the wiper if a warning is displayed (☞ P.4-16 [Replacing wipers]).
- Be careful to avoid leaving fragments from the cleaning stick behind when cleaning. These fragments will increase the risk of ejection failures (e.g., nozzle clogging or deflection).

1

With the screen in local mode, select [MENU] > [MAINTENANCE], and then press the [ENTER] key.

- The Maintenance menu is displayed.

2

Select [STATION MAINT.] > [CARRIAGE OUT] > [STATION MAINT.], and then press the [ENTER] key.

- The carriage moves over the platen.

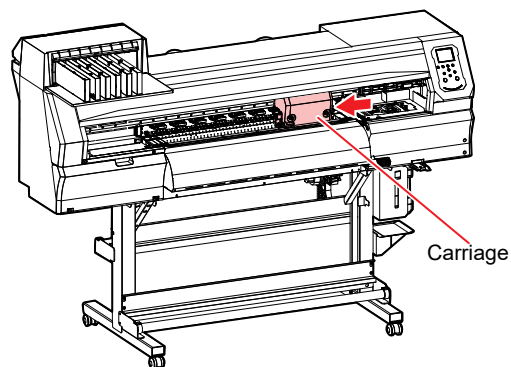

3

Remove the wiper.

- Pull out the wiper by holding the lugs at both ends.

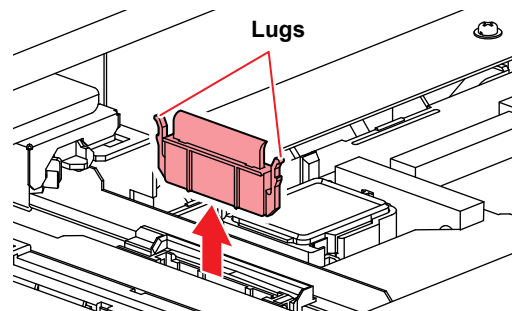

4

Clean the wiper and bracket.

- Wipe off any adhering ink or dust using a cleaning stick or tweezers moistened with maintenance liquid. Wipe off the maintenance liquid. Make sure none remains.



- When using tweezers, be careful not to damage the wiper with them.

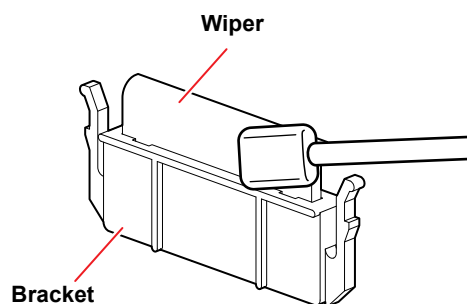

5

Clean the wiper slider.

- Use a cleaning stick moistened with maintenance liquid to wipe off any adhering ink or dust. Wipe off the maintenance liquid. Make sure none remains.

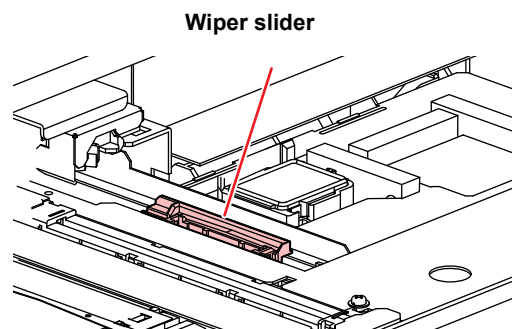

6 Return the wiper to its original position.

- Holding the wiper by the lugs at both ends, push it in.

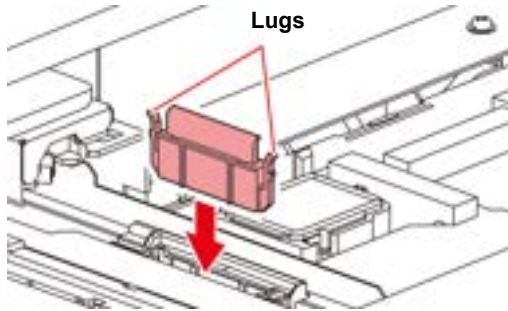
**7** Clean the cap rubber.

- Wipe off any adhering ink or dust using a cleaning stick or tweezers moistened with maintenance liquid. Wipe off the maintenance liquid. Make sure none remains.
- When using tweezers, be careful not to damage the wiper with them.
- If ink dry matter adheres to the cap rubber, it may cause cleaning failure.



[TxF150-75] Cap rubber

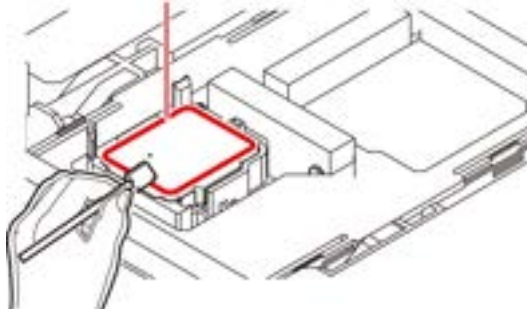

[TxF300-75] Cap rubber

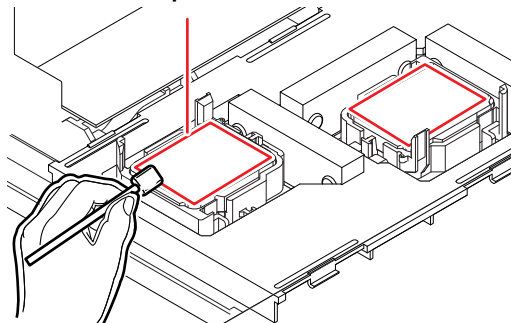
**8** Press the [ENTER] key after cleaning.**Cleaning the wiper cleaner**

Wipe off any adhering ink or dust using a cleaning stick or tweezers moistened with maintenance liquid.

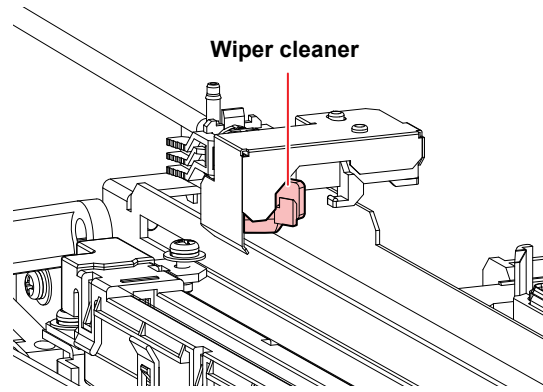

Remove the lower part of the ink guard when cleaning the wiper cleaner. Press the tabs and pull forward to remove it.

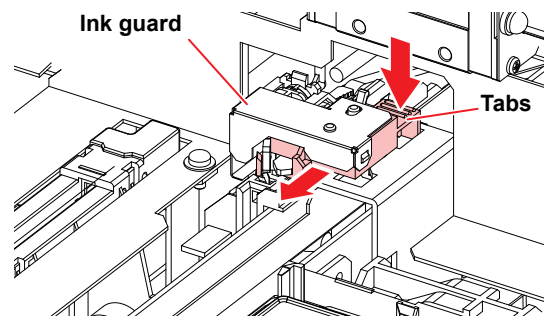

- Be careful not to pull out the tube.

**Cleaning the wiper ink guard**

Wipe off any adhering ink or dust using a cleaning stick or tweezers moistened with maintenance liquid.

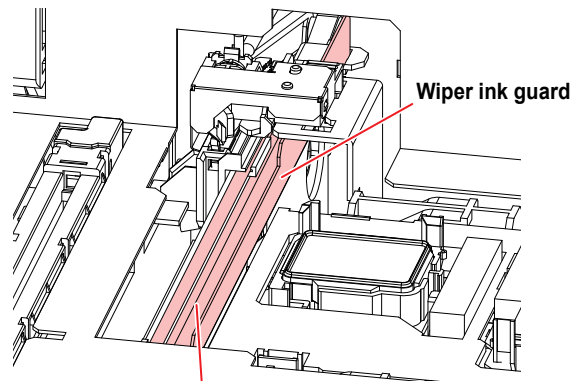

Use a cleaning stick or tweezers moistened with maintenance liquid to wipe off ink and dust in the red area of the illustration.

Cleaning under the carriage

The underside of the carriage becomes coated with ink wiped off by the wiper. Continuing to use the dirty carriage underside will rub dried ink and attached dust on to the media, resulting in contaminated prints.

The print head uses an extremely delicate mechanism. Take great care when handling it.



- Be careful to avoid leaving fragments from the cleaning stick behind when cleaning. These fragments will increase the risk of ejection failures (e.g., nozzle clogging or deflection).



- Never rub head nozzles.

1

With the screen in local mode, select [MENU] > [MAINTENANCE], and then press the [ENTER] key.

- The Maintenance menu is displayed.

2

Select [STATION MAINT.] > [CARRIAGE OUT] > [HEAD MAINT.], and then press the [ENTER] key.

- The carriage moves to the maintenance space.

3

Open the maintenance cover.

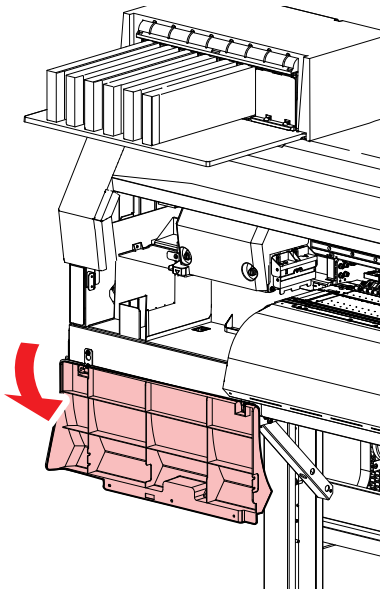

4

Wipe off any ink adhering to the sides of the head and under the carriage.

- Wipe off any ink, dust, ink dry matter and adhering using a cleaning stick moistened with maintenance liquid. Wipe off the maintenance liquid to make sure none remains.

[TxF150-75]

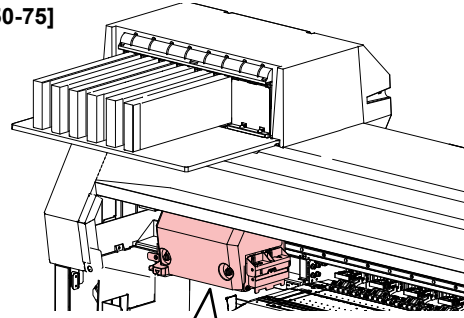

Clean the end side of head and the guard plate edge (the areas indicated in red) using a cleaning stick.

Never touch the nozzle surface!

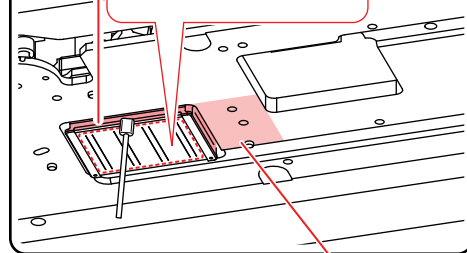

Clean with a cleaning stick, tweezers, or cloth.

[TxF300-75]

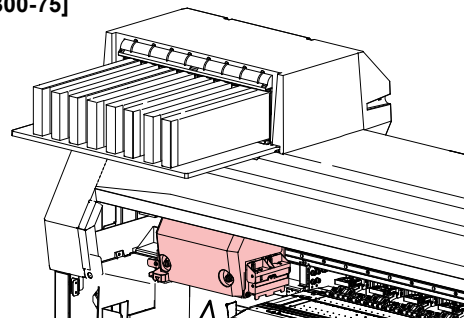

Clean the end side of head and the guard plate edge (the areas indicated in red) using a cleaning stick.

Never touch the nozzle surface!

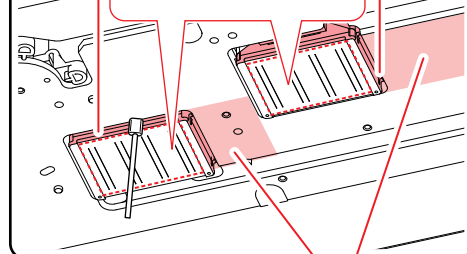

Clean with a cleaning stick, tweezers, or cloth.

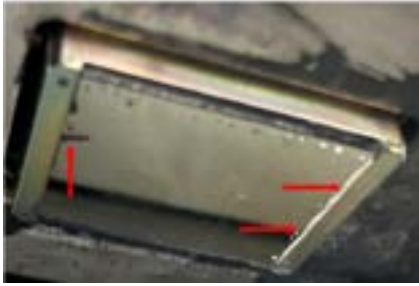

Wipe off the collected ink and other substances on the edges of the guard plate. (Arrow in red)



- Never rub the nozzles.

5

Press the [ENTER] key after cleaning.

6

Close the maintenance cover and press the [ENTER] key.

- After initialization, the machine returns to local mode.

NCU Cleaning

The NCU uses a sensor to monitor the ink droplets ejected from the print head nozzles. Continuing to use the dirty NCU may prevent the nozzle check function from operating correctly.



- Be careful to avoid leaving fragments from the cleaning stick behind when cleaning. These fragments will increase the risk of ejection failures (e.g., nozzle clogging or deflection).

1

On the LOCAL mode screen, select [MENU] > [Maintenance], then press the [ENTER] key.

- The Maintenance menu is displayed.

2

Select [Station Maint.] > [Carriage Out] > [Station Maint.], then press the [ENTER] key.

- The carriage moves over the platen.

3

Clean the NCU.

- Wipe off any ink and dust adhering using a cleaning stick moistened with maintenance liquid. Wipe off the maintenance liquid. Make sure none remains.

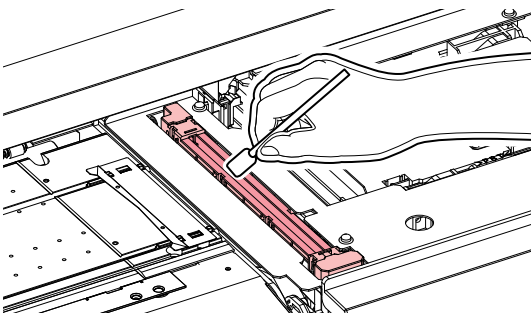

- Insert the cleaning stick as far as the line shown in the illustration.

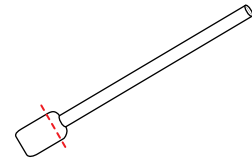

4

Press the [ENTER] key after cleaning.

Cleaning the waste ink draining channel

To prevent clogging of ink due to ink coagulation in the waste ink draining channel, clean the draining channel regularly (about once a week).

1

With the screen in local mode, select [MENU] > [MAINTENANCE], and then press the [ENTER] key.

- The Maintenance menu is displayed.

2

Select [STATION MAINT.] > [PUMP TUBE CLEANING], and then press the [ENTER] key.

- The carriage moves over the platen.

3

Press the [ENTER] key.

- The cap is filled with maintenance liquid (if the maintenance liquid cartridge is usable).
- Check whether the cap is filled with maintenance liquid.
- Pressing the [FUNC2] key enables additional filling with maintenance liquid.

[TxF150-75]

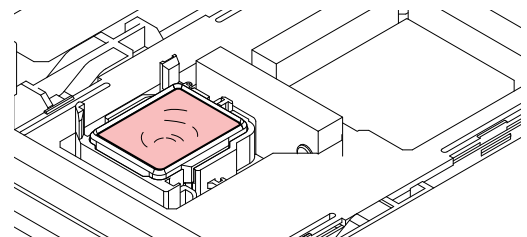

[TxF300-75]

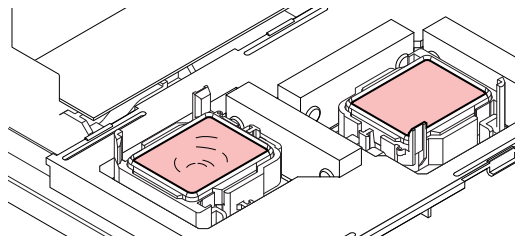



- If the maintenance liquid cartridge is usable, suck maintenance liquid into a dropper and fill up the cap with it. Fill up the cap with maintenance liquid on the verge of overflow from the cap.

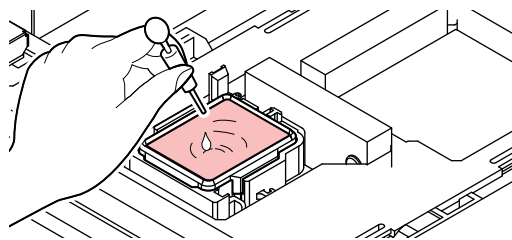

Illustration:TxF150-75

4

Press the [ENTER] key.

- Pump tube (ink discharge channel below the cap) washing starts.

Cleaning head nozzles

1

With the screen in local mode, select [MENU] > [MAINTENANCE], and then press the [ENTER] key.

- The Maintenance menu is displayed.

2

Select [STATION MAINT.] > [NOZZLE WASH], and then press the [ENTER] key.

- The carriage moves over the platen.

3

Clean the wiper and bracket, and then press [ENTER] key.

- P.4-4 [Cleaning the wiper and cap]

4

Clean the cap rubber and press the [ENTER] key.

- P.4-4 [Cleaning the wiper and cap]
- At this time, the channel is cleaned automatically.

5

Press the [ENTER] key.

- The carriage moves over the platen, and the cap is filled with maintenance liquid (if the maintenance liquid cartridge is usable).
- Check whether the cap is filled with maintenance liquid.
- Pressing the [FUNC2] key enables additional filling with maintenance liquid.

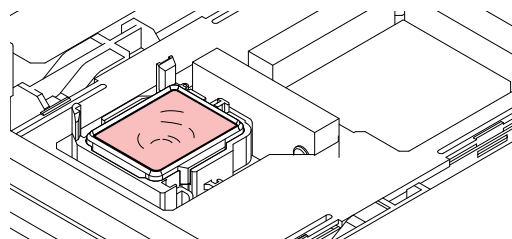

Illustration:TxF150-75



- If the maintenance liquid cartridge is usable, suck maintenance liquid into a dropper and fill up the cap with it. Fill up the cap with maintenance liquid on the verge of overflow from the cap.

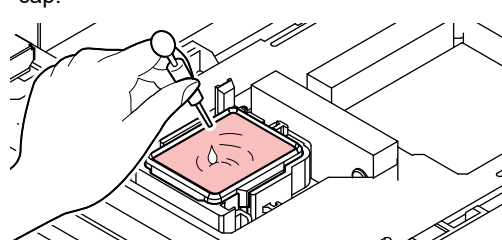

Illustration:TxF150-75

6

Set the leaving time, and then press the [ENTER] key.

- **Setting value:** 1–99 (in 1-minute increments)
- The nozzles are washed. The machine draws maintenance liquid from the cap.
- Cleaning is performed automatically after nozzle washing.



- If the nozzle clogging is not corrected even after you use this function several times, contact your dealer, or sales office (service call).

Preparing the machine if it will not be used over extended periods

Before leaving the machine idle for a week or more, use the cleaning function designed to be used before storage, which cleans head nozzles and the waste ink draining channel.

When leaving the machine for more than 2 days (regardless of the ambient temperature), be sure to clean the "cap edge", "wiper", and " carriage bottom surface" before use.



- If the "Check waste ink" warning message is displayed, check the waste ink tank. P.4-19 [In case of messages to check waste ink]

Tools required for cleaning

Check whether [Near End] or [Ink End] is displayed.

- Maintenance liquid and ink is aspirated during the washing operation. Washing is not possible if an error occurs during this process. Replace with new ink.

1 With the screen in local mode, select [MENU] > [MAINTENANCE], and then press the [ENTER] key.

- The Maintenance menu is displayed.

2 Select [STATION MAINT.] > [CUSTODY WASH], and then press the [ENTER] key.

- The carriage moves over the platen.

3 Clean the wiper and bracket, and then press [ENTER] key.

- P.4-4 [Cleaning the wiper and cap]

4 Clean the cap rubber and press the [ENTER] key.

- P.4-4 [Cleaning the wiper and cap]
- At this time, the channel is cleaned automatically.

5 Press the [ENTER] key.

- The carriage moves over the platen, and the cap is filled with maintenance liquid (if the maintenance liquid cartridge is usable).
- Check whether the cap is filled with maintenance liquid.
- Pressing the [FUNC2] key enables additional filling with maintenance liquid.

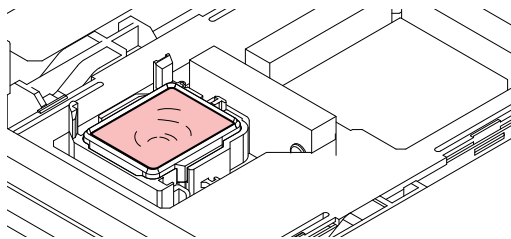

Illustration:TxF150-75



- If the maintenance liquid cartridge is usable, suck maintenance liquid into a dropper and fill up the cap with it. Fill up the cap with maintenance liquid on the verge of overflow from the cap.

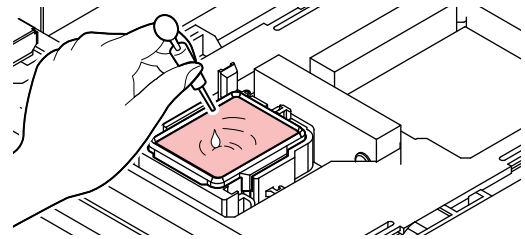

Illustration:TxF150-75

6 Set the leaving time, and then press the [ENTER] key.

- **Setting value:** 1–99 (in 1-minute increments)
- The nozzles are washed. The machine draws maintenance liquid from the cap.
- Cleaning is performed automatically after nozzle washing, after which the cap is filled with maintenance liquid.
- Check whether the cap is filled with maintenance liquid.
- Pressing the [FUNC2] key enables additional filling with maintenance liquid.

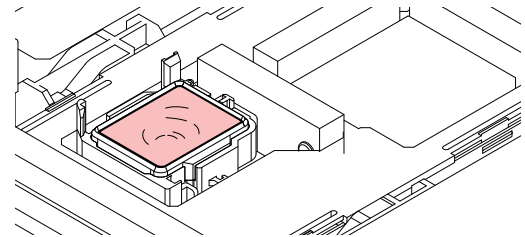

Illustration:TxF150-75



- If the maintenance liquid cartridge is usable, suck maintenance liquid into a dropper and fill up the cap with it. Fill up the cap with maintenance liquid on the verge of overflow from the cap.

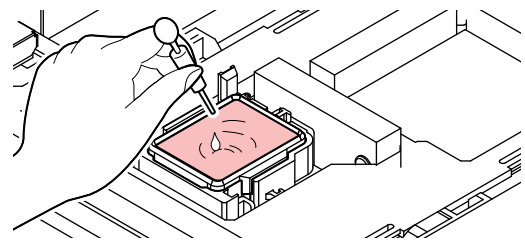

Illustration:TxF150-75

7 Press the [ENTER] key.

- Pump tube (ink discharge channel below the cap) washing starts.
- Do not turn off the main power supply. Turning off the main power supply will disable the automatic maintenance function (including nozzle clogging prevention function and ink discharge channel cleaning function). This increases the risk of ejection failures (such as nozzle clogging or deflection).
- Do not leave media loaded on the platen. This may leave irregularities or ripples in the media.



- If the "Check waste ink" warning message is displayed, check the waste ink tank. (P.4-19 [In case of messages to check waste ink])
- When the machine is not in use, raise the clamp lever to separate the pinch rollers from the grit rollers. Leaving the pinch rollers in the lowered position for an extended period of time may cause the pinch rollers to become deformed. Deformation of the pinch rollers may prevent the media from being fed correctly.

Cleaning media sensors

Media sensors are located on the rear cover and underside of the carriage. The media cannot be detected correctly if dust or debris accumulates on the sensors. Remove any debris using cotton swabs or a soft cloth. Before cleaning the sensor on the bottom of the carriage, move the carriage to the maintenance space.

Rear of machine

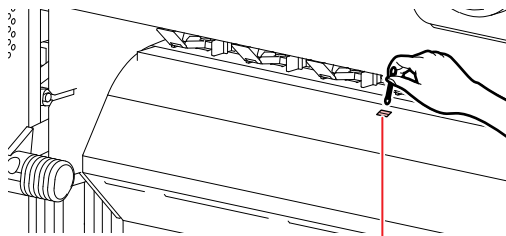

Media sensor

Underside of carriage

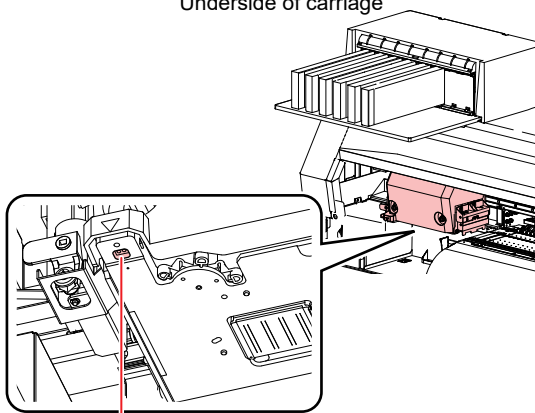

Media sensor



- Avoid touching the cutter blade near the media sensor. The sharp cutter tip poses a risk of injury.



- Never use solvents to clean the sensors.



- For heavy soiling, wipe using a soft cloth soaked in diluted neutral detergent and thoroughly wrung out.

Cleaning media holders



- Turn off the main power supply and unplug the power cable before carrying out maintenance.

Continuing to use the dirty platen will prevent proper feeding of the media. It will also cause dried ink and attached dust to rub against the head nozzle surface and lead to ejection failures (e.g., nozzle clogging or deflection).

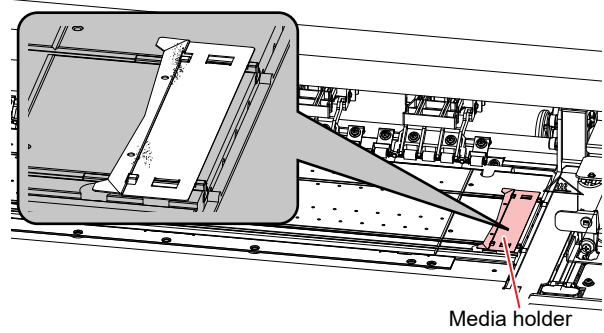

Media holder

Cleaning the platen



- Turn off the main power supply and unplug the power cable before carrying out maintenance.

Continuing to use the dirty platen will prevent proper feeding of the media. It will also cause dried ink and attached dust to rub against the head nozzle surface and lead to ejection failures (e.g., nozzle clogging or deflection).

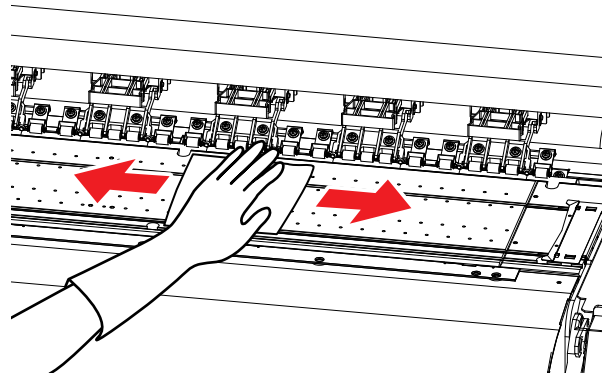

- Do not allow liquids to get inside the machine. Otherwise there is a risk of failure, electric shock, or fire.



- For heavy soiling, wipe using a soft cloth soaked in diluted neutral detergent and thoroughly wrung out.
- Wait until the platen has cooled sufficiently before cleaning it.
- Debris is more likely to accumulate in the grooves where the media holder slides and media is cut. Take care when removing any debris from there.

Cleaning exterior surfaces

When the exterior surfaces of the machine are dirty, wipe with a soft cloth dampened with neutral detergent diluted in water and thoroughly wrung out.

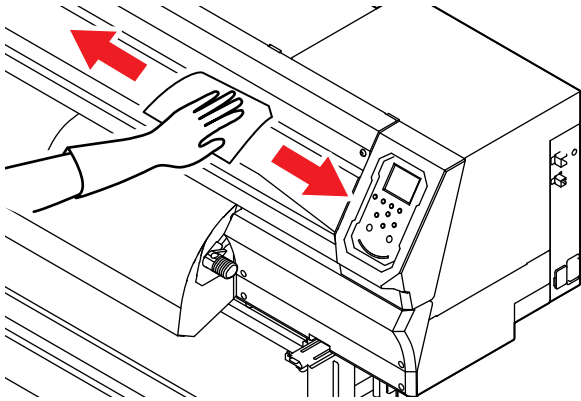

- Do not allow liquids to get inside the machine. Otherwise there is a risk of failure, electric shock, or fire.

Cleaning jam sensors

The jam sensor is located on the side of the carriage. Continuing to use it when it is dirty will rub dried ink and adhering dust onto media, resulting in dirty prints.

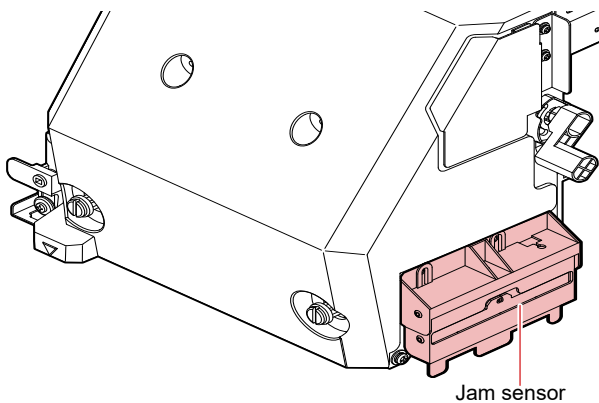

Maintenance Functions

Item		Setting	Meaning
Station Maint.			This moves the carriage to allow station and print head maintenance.
Carriage Out	Station Maint.	-	Cleans around the station, including the cap and wiper. P.4-4 [Cleaning the wiper and cap] P.4-17 [Replacing the CP pad set] P.4-17 [Replacing pinch rollers] P.4-18 [Replacing cutter blades]
	Head maintenance	-	Cleans around the print head. P.4-5 [Cleaning under the carriage] P.4-10 [Cleaning media sensors]
Nozzle Wash		1–99 min.	Washes the print head nozzle surface with maintenance liquid to resolve ejection failure (such as nozzle clogging or deflection). P.4-8 [Cleaning head nozzles]
Pump tube cleaning		-	Washes the suction pump tube (below the cap). P.4-7 [Cleaning the waste ink draining channel]
Custody Wash		1–99 min.	Perform this step if the machine will not be used for extended periods. Washes nozzles and drainage channels to keep the machine operating smoothly. P.4-9 [Preparing the machine if it will not be used over extended periods]
Replace Wiper		-	Use this function when replacing the wiper. Replacing the wiper resets the wiper usage counter. P.4-16 [Replacing wipers]
Maintenance Liquid		-	The cleaning route is filled with maintenance liquid to prevent ink coagulation in this path.
Nozzle Recovery			Allows other nozzles to be used for printing if maintenance actions like nozzle washing fail to resolve ejection failures (e.g., nozzle clogging or deflection). P.4-13 [Nozzle recovery function]
Print		-	Prints a pattern for checking and registering nozzle conditions.
Entry		-	Registers the nozzle without printing a pattern.
Reset		-	Initializes the details set.
TEST PRINT		ON/OFF	Enable nozzle recovery on test prints.
Auto Maint.			Sets various maintenance actions to be performed automatically. Set the interval between individual maintenance actions. P.4-14 [Auto Maintenance Functions]
Refresh		0.5–1.0 hr.	Set the interval between executing refresh.
Pump Tube & Nozzle Wash		-	Set the interval for waste ink draining channel cleaning/head nozzle cleaning and the time for leaving during head nozzle cleaning. Setting a leaving time will leave the nozzle surface immersed in the maintenance liquid before cleaning. This helps to prevent nozzle clogging.
Cleaning (Interval)		1–12 hr.	Set the interval between cleaning.
Cleaning (Type)		Normal / Soft / Hard	Set the type of cleaning.
White maintenance		-	Improves nozzle dropout and ejection failure of white ink.
Fill Up Ink		-	Supplies ink to alleviate nozzle clogging. P.4-15 [Filling with ink]
Replace Wasteinktank		-	Resets or corrects the waste ink tank usage count. P.4-19 [Waste Ink Tank]
PinchRoller replacement		-	Replace pinch roller and reset used distance. P.4-17 [Replacing pinch rollers]

Nozzle recovery function

When nozzle clogging of specific nozzles cannot be corrected, other nozzles working normally can be used instead for printing. This is referred to as nozzle recovery.

1 With the screen in local mode, select [MENU] > [MAINTENANCE], and then press the [ENTER] key.

- The Maintenance menu is displayed.

2 Select [NOZZLE RECOVERY] > [PRINT], and then press the [ENTER] key.

- A nozzle recovery pattern is printed.
- The Select Entry Nozzle screen appears once printing is complete.
- Selecting "ENTRY" will skip printing and go to the next step.

[TxF150-75]

View from above the print head

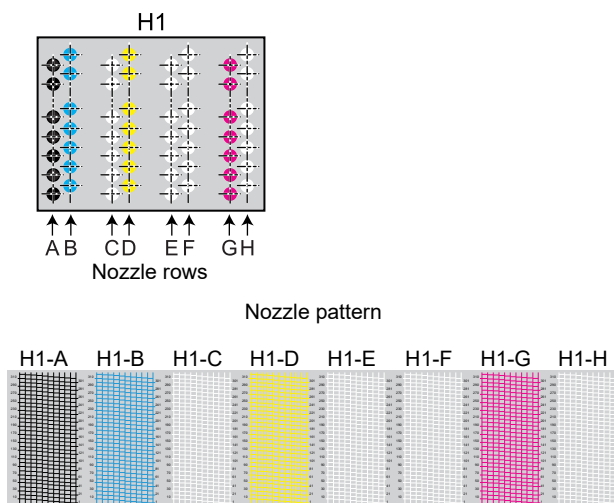

[TxF300-75]

View from above the print head

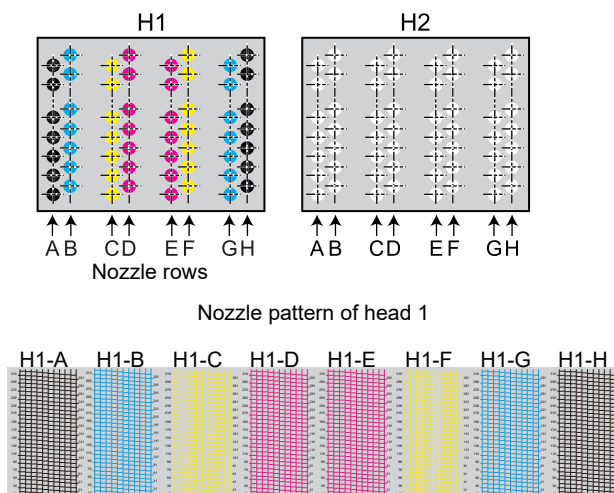

3 Select head numbers and nozzle rows for nozzle recovery, and then press the [ENTER] key.

- Select nozzle rows and press the [ENTER] key.

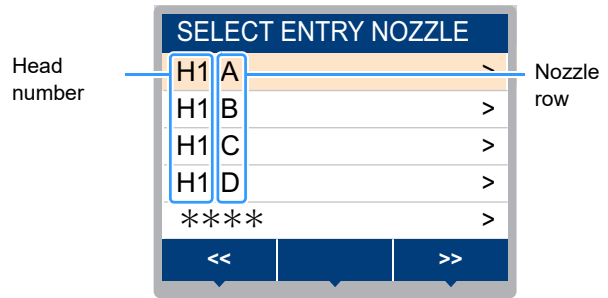

4 Enter nozzle numbers for nozzle recovery, and then press the [ENTER] key.

- (1) Select numbers to enter (1–10) by pressing the [▲]/[▼] key, and then press the [ENTER] key.
- (2) Enter nozzle numbers for recovery by pressing [▲]/[▼] key, and then press the [ENTER] key.

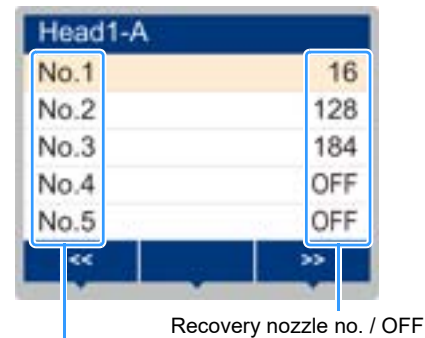

Number of entry: 1–10

Example of entering recovery nozzles

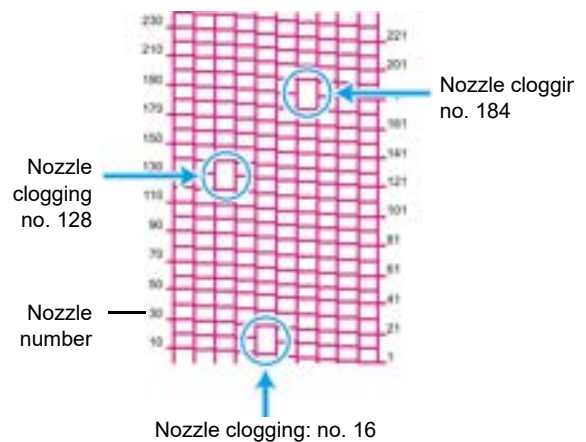

- Up to 10 nozzles can be entered per nozzle row.
- Using this function does not alter the time required for printing.
- Nozzle recovery is not reflected if printing in the lowest pass. Moreover, only some nozzles may be valid depending on the conditions. Perform a trial print once to confirm.

Resetting your set values

1 With the screen in local mode, select [MENU] > [MAINTENANCE], and then press the [ENTER] key.

- The Maintenance menu is displayed.

2 Select [NOZZLE RECOVERY] > [RESET], and then press the [ENTER] key.

- [Nozzle Recovery] is automatically selected.
- [RESET] is automatically selected.

3 Select nozzle rows to reset and press the [ENTER] key.

- A reset confirmation message is displayed.

4 Press the [ENTER] key.

Auto Maintenance Functions

Provides a variety of convenient automatic maintenance settings.



- Automatic maintenance functions are disabled if the warning message "Replace Waste Ink Tank" appears. P.4-19 [Waste Ink Tank]

- When the power switch is turned off, check the waste ink tank.



- After all manual maintenance is performed and the specified time has elapsed, automatic maintenance will start.

Setting the refresh interval

Set the interval between ejection of a small amount of ink from the nozzles to prevent nozzle clogging.

1 With the screen in local mode, select [MENU] > [MAINTENANCE], and then press the [ENTER] key.

- The Maintenance menu is displayed.

2 Select [AUTO MAINT.] > [REFRESH], and then press the [ENTER] key.

3 Set the refresh interval and press the [ENTER] key.

Setting the pump tube & nozzle wash interval

To prevent ink clogging due to ink coagulation on the waste ink draining channel and head nozzle surface, set intervals for cleaning these areas. When cleaning head nozzles, also set the leaving time (for immersing the nozzle surface in maintenance liquid in the cap).



- When using this auto maintenance function, always confirm that maintenance liquid is loaded. Tube/nozzle cleaning cannot be performed unless maintenance liquid is loaded. This poses a risk of clogging the channel and head nozzles.
- Hard cleaning is performed to wash the nozzles (approx. 33 ml of ink is consumed each time). Note that if this cleaning cannot be performed (such as when there is not enough ink), only the tube is cleaned, and nozzle washing will not take place.

1 With the screen in local mode, select [MENU] > [MAINTENANCE], and then press the [ENTER] key.

- The Maintenance menu is displayed.

2 Select [AUTO MAINT.] > [PUMP TUBE & NOZZLE WASH] > [INTERVAL], and then press the [ENTER] key.

3 Set the pump tube/nozzle washing interval, and then press the [ENTER] key.

- **Setting value:** 24–48 (hr.)
Setting values vary depending on the type of ink used.

4 Select [LEAVING TIME] and press the [ENTER] key.

5 Set the time to leave the head nozzle surface immersed in maintenance liquid, and then press the [ENTER] key.

- **Setting value:** OFF / 1–99 (in 1-minute increments)
- Setting this value to OFF will skip nozzle cleaning. Only pump tube cleaning is performed.



- The default settings are "48h" for washing interval time of the nozzle and "1min" for leaving time. **The recommended value is 1 minute.**

Setting the interval and type of cleaning

This function is used instead of pump tube/nozzle washing when the maintenance liquid has been used up. Set the type of cleaning and the interval between cleaning.

1 With the screen in local mode, select [MENU] > [MAINTENANCE], and then press the [ENTER] key.

- The Maintenance menu is displayed.

2 Select [AUTO MAINT.] > [INTERVAL] or [TYPE], and then press the [ENTER] key.

- **Interval setting value:** 1–12 h
- **Type setting value:** SOFT / NORMAL / HARD

Filling with ink

Supplies ink to alleviate nozzle clogging.

1 With the screen in local mode, select [MENU] > [MAINTENANCE], and then press the [ENTER] key.

- The Maintenance menu is displayed.

2 Select [FILL UP INK] and press the [ENTER] key.

3 Selecting the type of filling.

- **NORMAL** : If the nozzle dropout does not recover after hard cleaning, if the nozzle dropout occurs during printing (If the nozzle is missing white ink, perform [MAINTENANCE] > [White Maintenance]).
- **HARD** : If the nozzle condition does not recover after normal ink fillin.

4 Press the [ENTER] key.

- Ink is supplied automatically.

Replacing Consumables

To order replacement consumable items, contact your local dealer or our service office. For more information on consumable items, refer to our website.
<https://mimaki.com/supply/inkjet.html>

Replacing wipers

When a [Replace Wiper] warning message is displayed, the wiper must be replaced with a new one. Also at this time, wipe away ink adhering to the bottom of the slider.

- Important!**
- After a wiper replacement warning appears, confirm that the top edge of the wiper film is free of damage or fluff, etc. If there is no damage or fluff at the top edge of the wiper film, it can still be used.

1 With the screen in local mode, select [MENU] > [MAINTENANCE], and then press the [ENTER] key.

- The Maintenance menu is displayed.

2 Select [STATION MAINT.] > [REPLACE WIPER], and then press the [ENTER] key.

- The carriage moves over the platen.

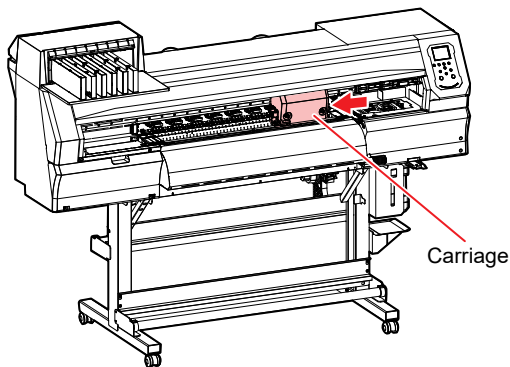

3 Remove the wiper.

- Pull out the wiper by holding the lugs at both ends.

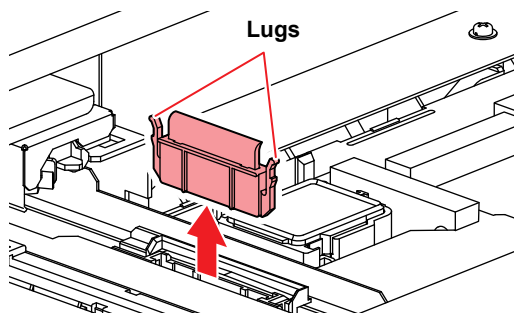

4 Clean the wiper slider.

- Use a cleaning stick moistened with maintenance liquid to wipe off any adhering ink or dust. Wipe off the maintenance liquid. Make sure none remains.

Wiper slider

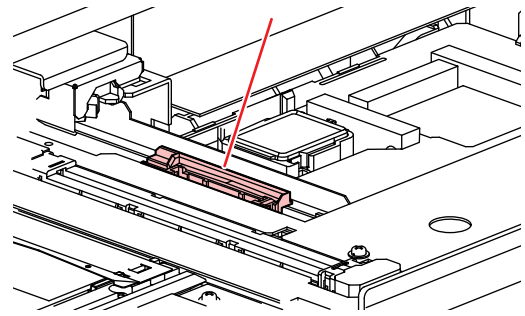

5 Insert a new wiper.

- Holding the wiper by the lugs at both ends, push it in.

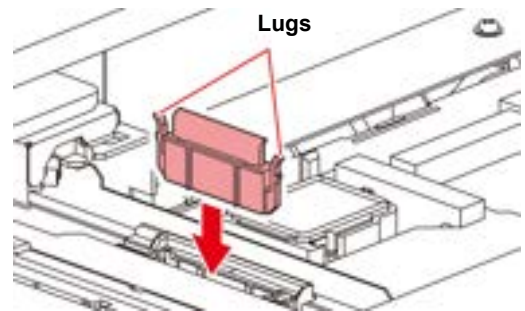

6 Press the [ENTER] key.

- After initialization, the machine returns to local mode.

Replacing exhaust box filters

Check the exhaust fan filter condition. Replace if very dirty.



- Replace the very dirty exhaust fan box with new one.

1 Remove the exhaust fan box.

- Push the tabs at the front to remove the exhaust fan box.

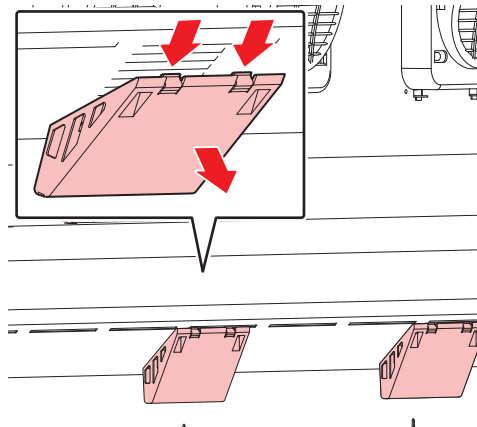

2 Attach a new exhaust fan filter to the exhaust fan box.

- Insert the exhaust fan filter into the space under the tabs of the exhaust fan box.

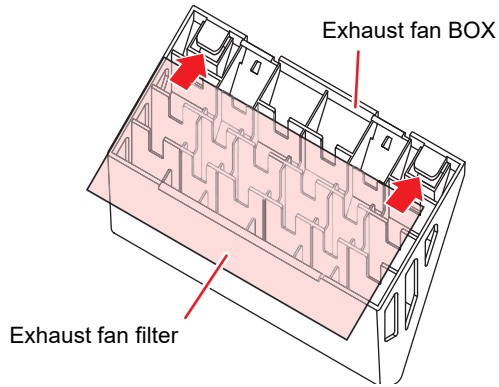

3 Attach the exhaust box in its original position.

- Engage the tabs at the rear of the exhaust box onto the machine, and then push in the front side.

Replacing the CP pad set

If the CP pad set is very dirty or if ink drips onto the media, replace with a new cap absorber.

1 With the screen in local mode, select [MENU] > [MAINTENANCE], and then press the [ENTER] key.

- The Maintenance menu is displayed.

2 Select [STATION MAINT.] > [CARRIAGE OUT] > [STATION MAINT.], and then press the [ENTER] key.

- The carriage moves over the platen.

3 Remove the CP pad set.

- Push up the two tabs at the front to remove the cap absorber.

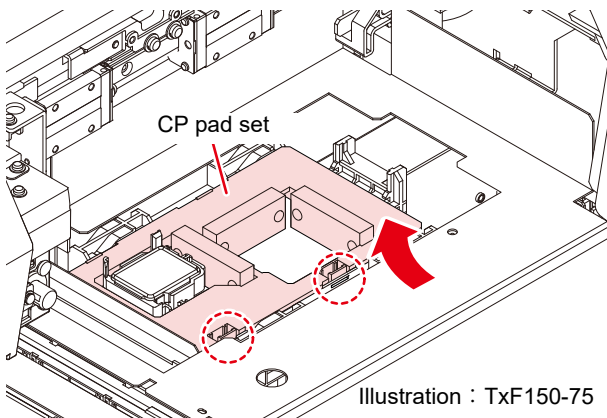

4 Attach the new CP pad set.

- Push the tabs of the CP pad set into the slits at the rear of the C slider, then insert the tabs at the front.

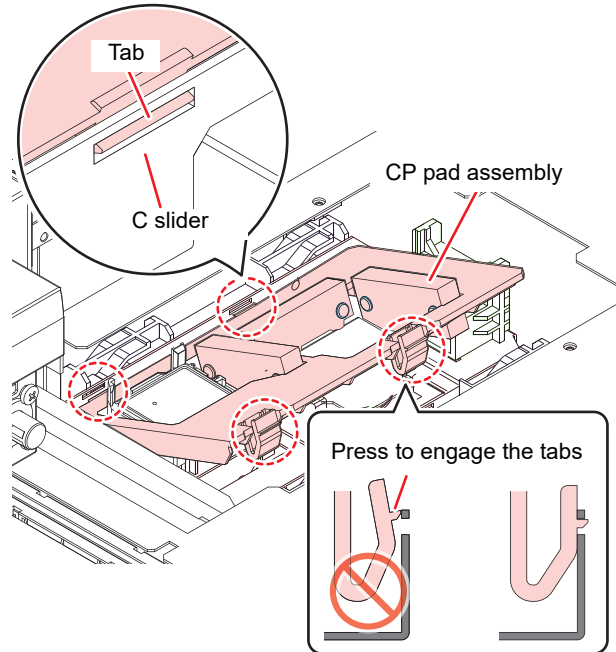

5 After replacement, manually return the wiper to the rear.

6 Turning On the Power

- Check to confirm that the carriage returns to the station.

Replacing pinch rollers

After a certain period in use, the pinch rollers may be worn out, leaving roller marks on the printed results.

When the message "Replace pinch roller." is displayed in local mode, replace the pinch roller as soon as possible.

Similarly, replace the pinch roller with a new pinch roller if it is dirty or severely worn out.



- Turn off the main power supply and unplug the power cable before carrying out maintenance.



- Do not use maintenance liquids, or alcohol, etc.

1

Raise the clamp lever.

2 Remove the O-rings holding the pinch rollers.



- The O-rings are small. Be careful to avoid dropping them into the product interior.

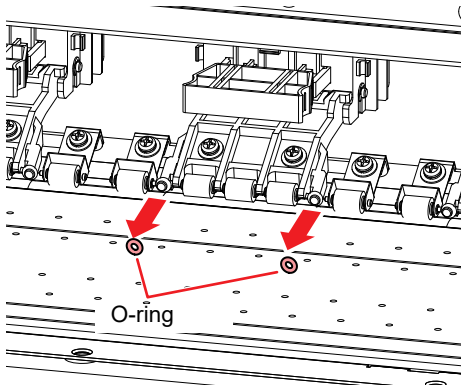

3 Remove the pinch rollers.

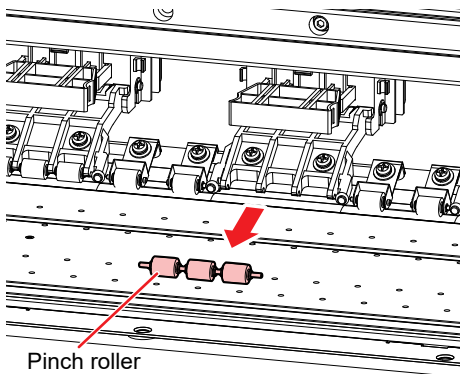

4 Replace the O-rings and pinch rollers.

5 Attach the pinch rollers and secure them with the O-rings.

6 Turn the power on.

7 Select [MENU] > [MAINTENANCE] > [Pinch Roller Replacement] in local mode and press the [ENTER] key.

- After performing it, the exchange message disappears.

Replacing fan filters

Replace the blowing fan filter if it is dirty.



- Turn off the main power supply and unplug the power cable before carrying out maintenance.

1 Remove the fan filter cover.

- Push the fan filter cover claw outward, and pull the cover to the front.

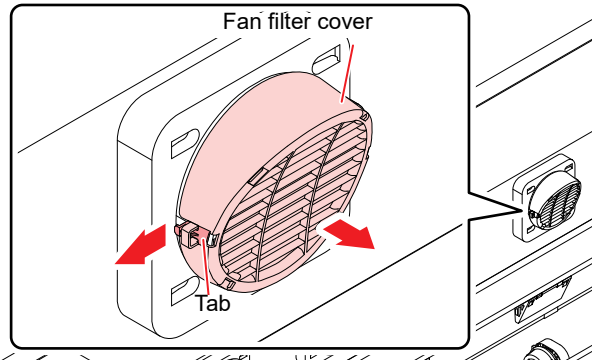

2 Remove the filter.

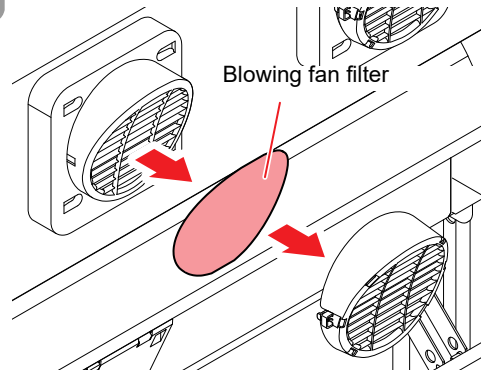

3 Mount a new filter, along with the fan filter cover.

- Push in the fan filter cover until the tab clicks.

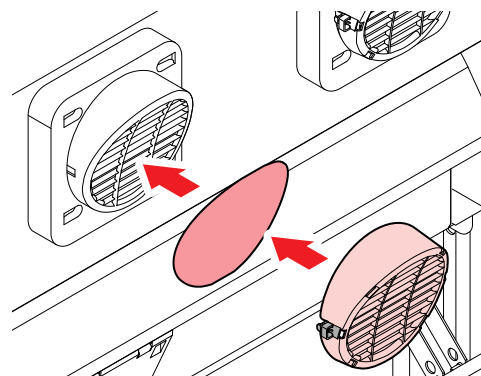

Replacing cutter blades

Replace cutters when blades are chipped or blunt.



- Avoid touching the cutter blade. Failure to do so may result in injury.



- Avoid storing this product in locations accessible to children.

- 1 With the screen in local mode, select [MENU] > [MAINTENANCE], and then press the [ENTER] key.

- The Maintenance menu is displayed.

- 2 Select [STATION MAINT.] > [CARRIAGE OUT] > [STATION MAINT.], and then press the [ENTER] key.

- The carriage moves over the platen.

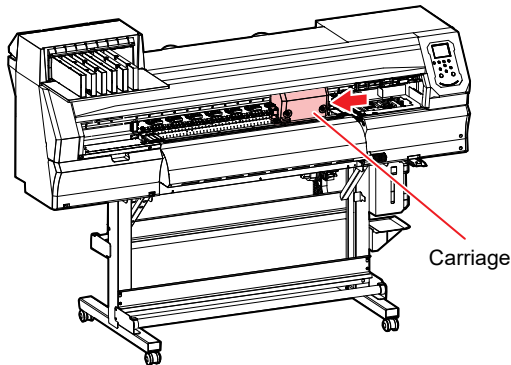

- The carriage can be moved by hand. Move the carriage slowly to a position allowing easy replacement.

- 3 Replace the cutter.

- (1) Unscrew the cutter screw.
- (2) Remove the cutter.
- (3) Mount a new cutter.
- (4) Tighten the screw to clamp the cutter.

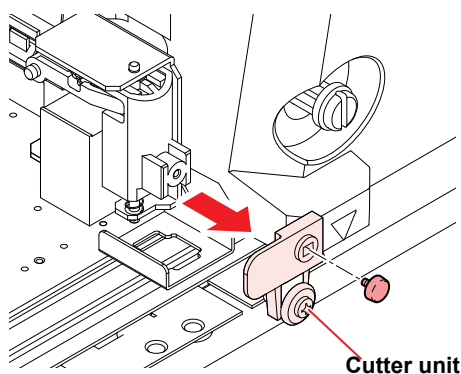
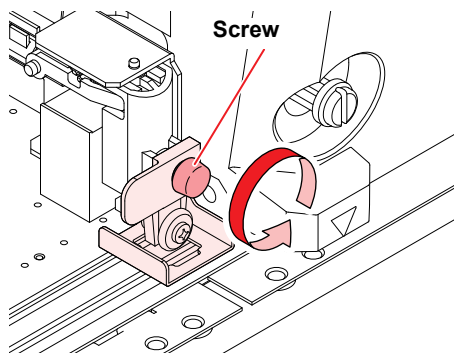

- 4 Press the [ENTER] key.

Waste Ink Tank

Ink used during head cleaning and other processes is collected in the waste ink tank at the lower right of the machine.

The machine keeps track of the waste ink level. A "Check Waste Ink Tank" message appears when the preset level is reached. Use this a guide for replacing the waste ink tank.



- The message is displayed when it reaches 80% (1.6L) of the 2L tank.

In case of messages to check waste ink

Confirmation message in local mode

- 1 Check Waste Ink is displayed.

- 2 Check the waste ink tank.

- If there is an error with the actual amount, press [▲]/[▼] to correct.
- Correct to less than 80% and press the [ENTER] key to clear the message.
- If there is no discrepancy, replace (dispose of) the waste ink tank referring to P.4-19 [Replacing the waste ink tank].



- Check the level in the waste ink tank frequently. Continuing to use the machine without disposing of waste ink may result in waste ink overflowing from the tank.

Replacing the waste ink tank

- 1 With the screen in local mode, select [MENU] > [MAINTENANCE], and then press the [ENTER] key.

- The Maintenance menu is displayed.

- 2 Select [REPLACE WasteInkTank] and press the [ENTER] key.

- 3 Pull the waste ink tank stopper forward.

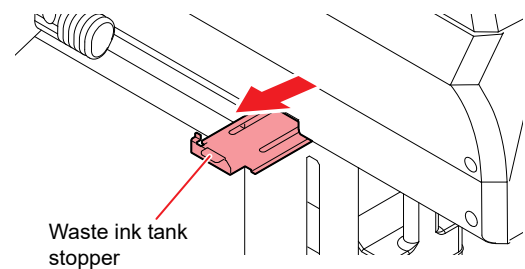

- 4 Hold the waste ink tank handle and pull it toward the front to remove it.

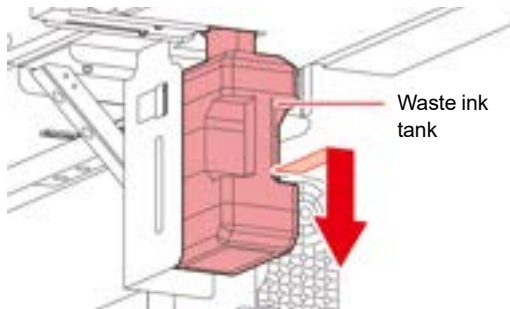

Important!

- Attach the cap to the removed waste ink tank, and use tape to prevent leakage of waste ink.



- Request an industrial waste disposal company to dispose of waste ink.

5

Mount a new waste ink tank.

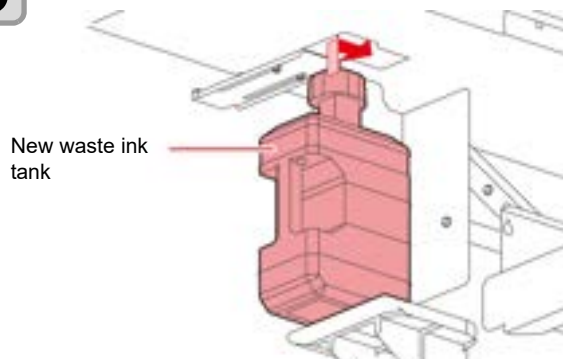

6

Close waste ink tank stopper.

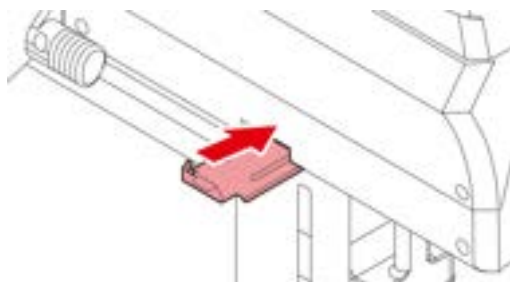

7

Press the [ENTER] key.

- The waste ink level will be reset.

Examples of Printing Issues

The following are typical examples of head (nozzle) ejection failure caused by dust or other factors that affect printing. To avoid using the nozzles in this state, check the nozzles regularly before and during printing. Nozzle status can be checked by using the machine's test printing function.

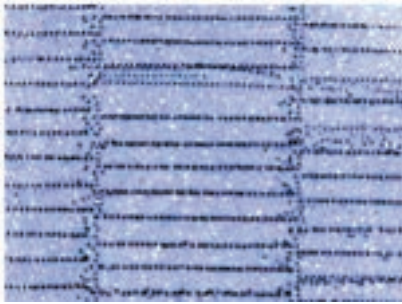

1. Nozzle deflection



2. Nozzle clogging



3. Ink dripping



4. Mist

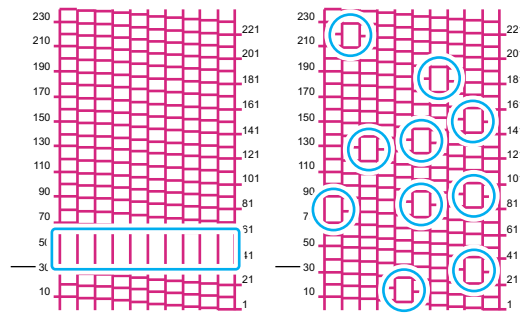

5. Mixing with air



- If condensation occurs on the head surface, a dispensing failure may occur.

If condensation occurs, try the following.

1. Raise the room temperature.
2. Lower the heater temperature.
3. Turn on the top blower.
4. Reduce the ink density.



Recovering from nozzle ejection failure

If the machine is idle over an extended period, or under certain ambient temperatures, discharging from nozzles may become unstable. The following nozzle recovery is available.

For symptoms in figures 1–4 above

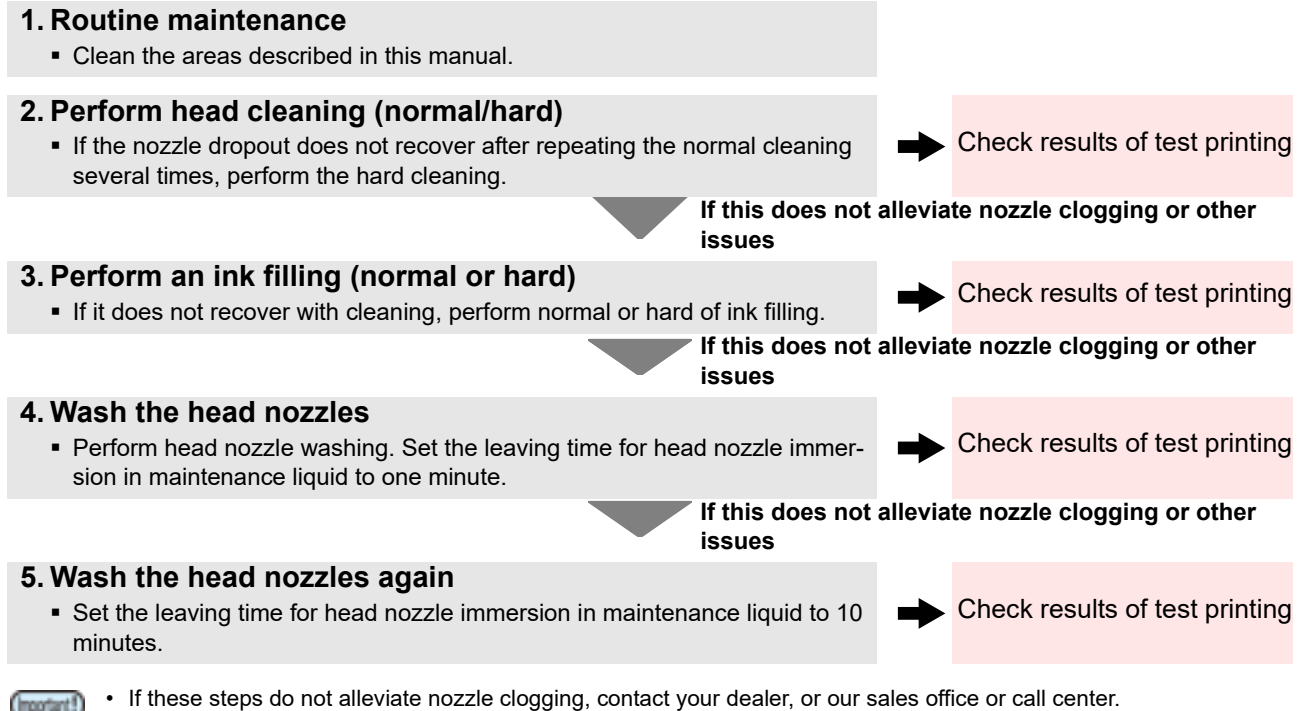

Recovering from frequent nozzle dropout and nozzle ejection failures of white

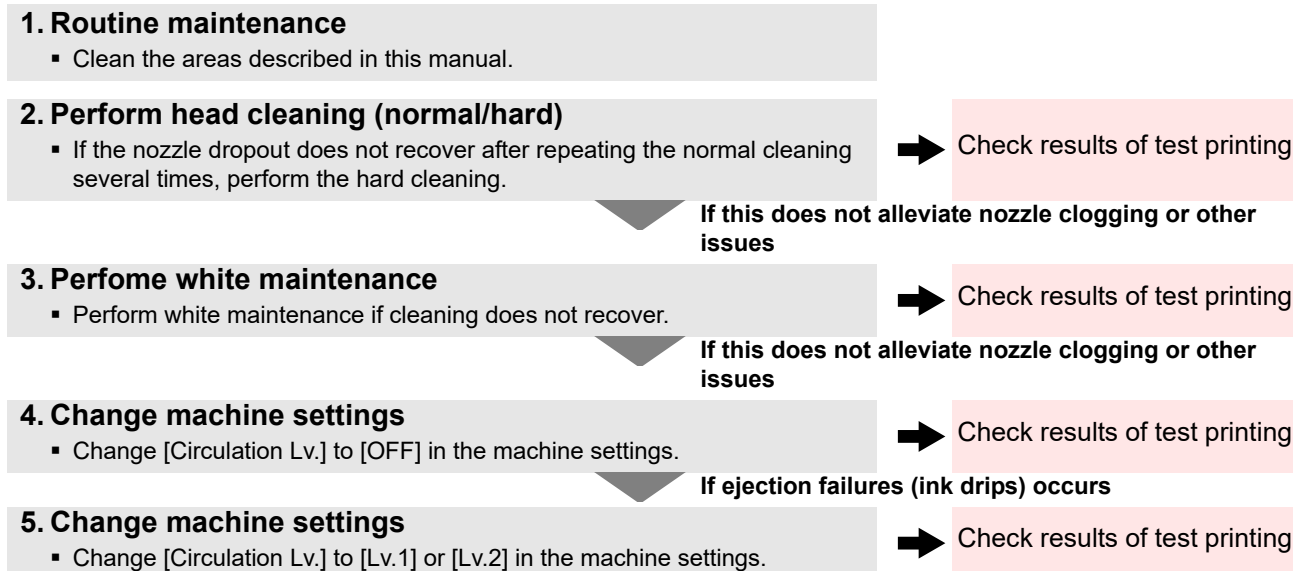

Chapter 5 Troubleshooting



About this chapter

This chapter describes the essentials for keeping the machine operating smoothly, such as routine care, and ink cartridge maintenance.

Troubleshooting	5-2
Power does not turn on	5-2
Printing is not possible	5-2
Media jams or is dirty	5-2
Heater temperature does not rise to the set level	5-2
Image quality is poor	5-3
Nozzles are clogged	5-3
Ink cartridge warning appears	5-3
Ink leakage occurs	5-3
Warning/Error Messages	5-4
Warning messages	5-4
Error messages	5-6

Troubleshooting

Double-check the following points if you suspect mechanical failure. If the corrective action does not resolve the problem, contact your dealer, or our sales office or call center.

Power does not turn on

This is usually due to incorrect connection of the power cable for the machine or computer. Confirm that the equipment is connected correctly.

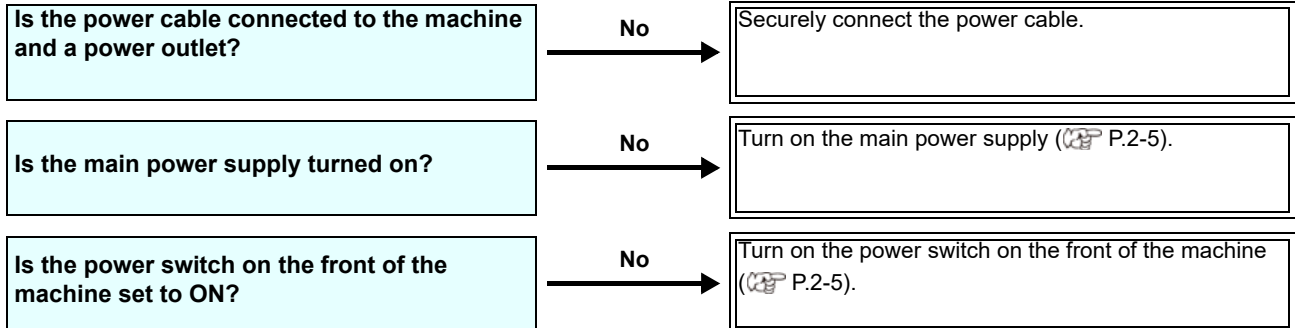

Printing is not possible

This occurs when data is not transmitted to the machine correctly. It may also occur when printing functions are not working correctly or media is not loaded correctly.

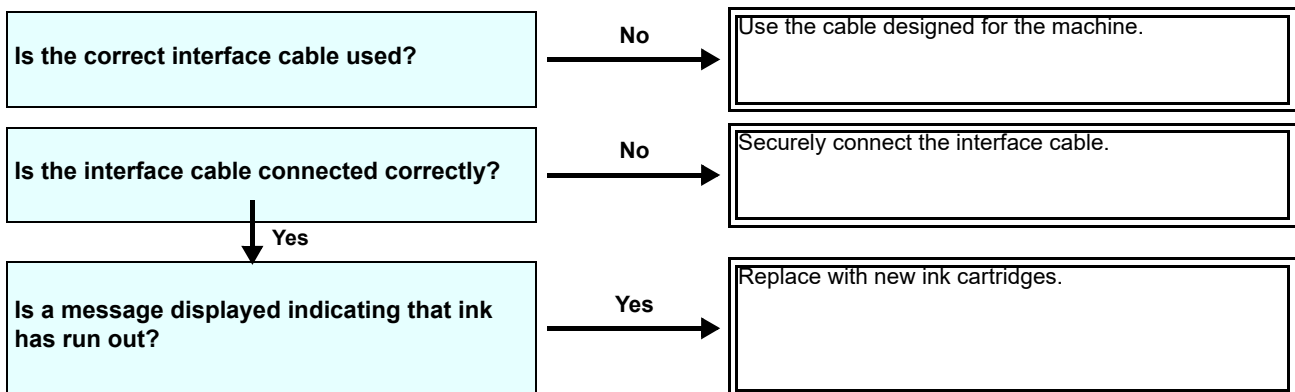

Media jams or is dirty

Media jamming or becoming dirty may be due to using unsuitable media or loading it incorrectly.

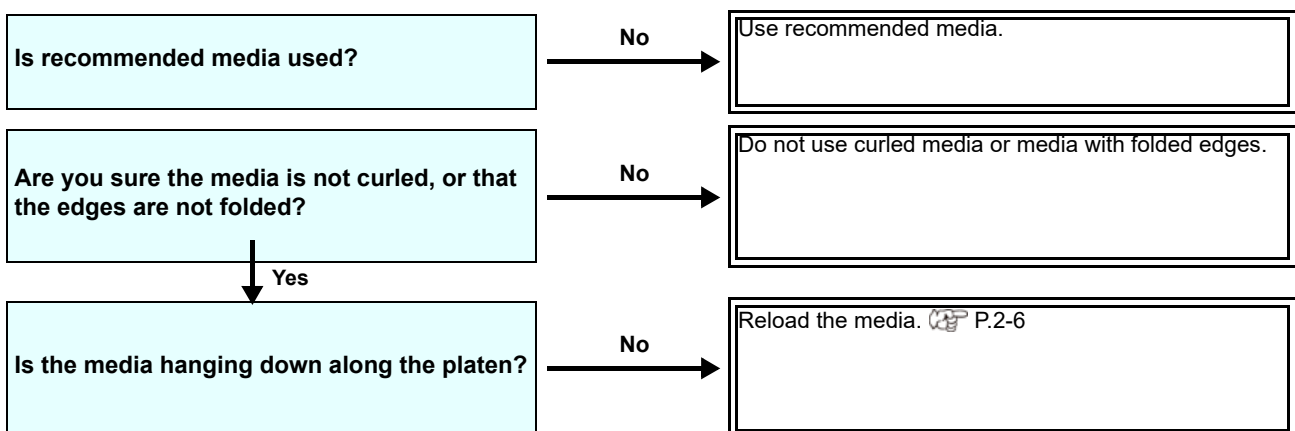

Heater temperature does not rise to the set level

Check basic machine operations.

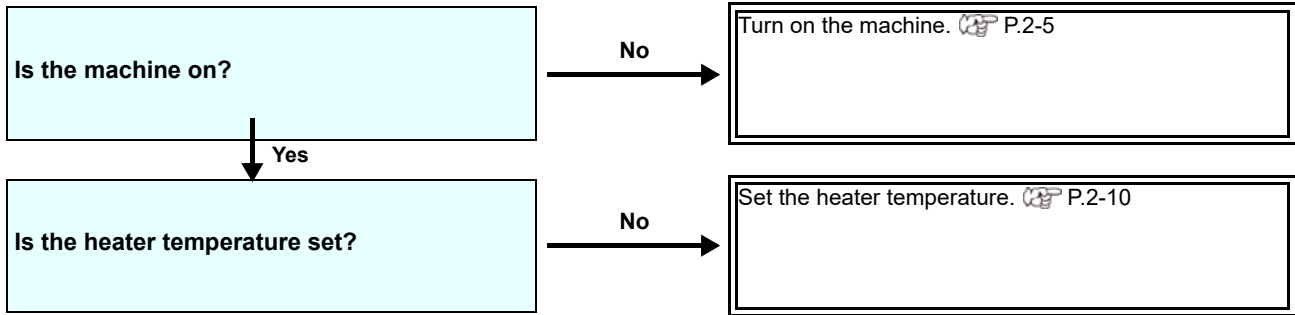

Image quality is poor

This section describes corrective actions for image quality issues. Take the corrective action for the particular symptom. If the issue persists, contact your dealer, or our sales office or call center.

Symptom	Corrective action
White stripes/blurring/dark stripes occur (in the carriage scanning direction).	(1) Perform head cleaning. P.2-11 (2) Perform maintenance in the station. P.4-4 (3) Execute the [FEED COMP.] function. P.2-12 (4) Remove any paper scraps or other debris adhering to areas over which the head passes, such as the media holder.
Text is double- or triple-printed in the media feed direction.	(1) Execute the [FEED COMP.] function. P.2-12
Misalignment occurs in bidirectional printing.	(1) Execute the [DROP.POScorrect] function. P.2-13
Ink droplets drip during printing.	(1) Clean the wiper. P.4-4 (2) Perform ink cap cleaning. P.4-4 (3) Clean the underside of the carriage. P.4-5 (4) Perform [NORMAL] head cleaning. P.2-11 (5) Set up [INTERVAL WIPING]. P.3-6

Nozzles are clogged

When nozzle clogging is not resolved even after head cleaning (P.2-11), check the following.

- Follow the steps in P.4-8 [Cleaning head nozzles].
- Follow the steps in P.4-5 [Cleaning under the carriage].
- Follow the steps in P.4-13 [Nozzle recovery function].

Ink cartridge warning appears

If an ink cartridge issue occurs, the cartridge LED will light in red and a warning message is displayed. All operations involving ink discharge, such as printing and cleaning, are disabled. Replace with new ink cartridges.



- Once an ink cartridge warning appears, do not leave the machine in that state over an extended period. Nozzle clogging prevention will be disabled. If the nozzles are clogged, the machine must be repaired by a Mimaki service engineer.

Displaying cartridge warning details

Cartridge warning details can be checked as follows.

- 1 In local mode, press the [ENTER] key.
- 2 Press the [ENTER] key.

Ink leakage occurs

If ink leaks, turn off the main power switch, unplug the machine, and contact your dealer or our sales office or call center.

Warning/Error Messages

If a problem arises, the buzzer sounds and a message is displayed. Take appropriate measures based on the message.

Warning messages

Errors when performing operations

Message	Cause	Corrective action
INVALID OPERATION :!MEDIA UNDETECTED	Operation cannot be performed because no media was detected.	• Try again after media is detected.
INVALID OPERATION :MOTOR POWER OFF	The motor was deactivated because the cover was opened, for example.	• Return to local mode and try the operation again after initialization.
INVALID OPERATION :INK ERROR	An ink error occurred.	• Try again after replacing with new ink cartridges.
INVALID OPERATION COVER OPEN	The cover is open.	• Try again after closing the cover.
INVALID OPERATION DATA REMAIN	Data was received.	• Try again after clearing the data (☞ P.2-14).

Messages displayed in local mode

Message	Cause	Corrective action
!Can't PRINT/CARTRIDGE	Multiple ink errors (unusable ink) have occurred, preventing ink supply (printing, cleaning, etc.).	• Replace with new ink cartridges.
Check Waste Ink	The waste ink tank count has exceeded the specified amount.	• Check the amount of waste ink in the waste ink tank. • Perform maintenance and waste ink tank replacement, and then reset the amount of waste ink.
REPLACE WIPER	The wiping count has exceeded the specified amount.	• Perform maintenance, station maintenance, and wiper replacement.
HEATER TEMP ERROR POWERED OFF	Displayed on startup following [ERROR 710 HEATER TEMP ERROR], after the power is manually turned off.	• If Error 710 appears again, contact your dealer, or our sales office or call center.
NO MEDIA	No media is loaded. Otherwise, sensor failure has occurred.	• Load media. If the message appears when media is loaded, contact your dealer, or our sales office or call center.
DATA REMAIN	Print data was received in local mode.	• Switch to remote mode and start printing. Otherwise, clear the data and cancel printing.
MACHINE TEMP./H **° C	Temperature in the environment where the machine is installed is too high, preventing stable printing.	• Adjust the ambient temperature to be within the specified range (20–35°C).
MACHINE TEMP./L **° C	Temperature in the environment where the machine is installed is too low, preventing stable printing.	
Wash liquid cartridge none	No maintenance washing liquid cartridge is loaded. Wiper washing and tube/nozzle washing (auto maintenance operations) cannot be performed.	• Load a maintenance washing liquid cartridge.
Washing liquid end	There is no remaining maintenance liquid. Wiper washing and tube/nozzle washing (auto maintenance operations) cannot be performed.	• Replace with a new cleaning solution cartridge.
Replace PinchRollers	The pinch roller has been used for a certain distance and may have roller marks on the media.	• Replace the pinch roller and perform [Replace PinchRollers].

Ink errors

Ink errors are also displayed in local guidance (☞ P.3-19 [Displaying information]).

Message	Cause	Corrective action
Wrong Ink IC	The ink IC chip of the ink cartridge cannot be read correctly.	<ul style="list-style-type: none"> Reinsert the cartridge that caused the warning. If the warning persists, contact your dealer, or our sales office or call center.
INK TYPE	The type of ink in the ink cartridge is different from the ink currently supplied.	<ul style="list-style-type: none"> Check the type of ink in the cartridge that caused the warning.
INK COLOR	The color of ink in the ink cartridge is different from the ink currently supplied.	<ul style="list-style-type: none"> Check the color of ink in the cartridge that caused the warning.
Wrong Cartridge	An error occurred with the ink IC chip information for the ink cartridge. Amount used exceeds the stipulated value.	<ul style="list-style-type: none"> Replace the cartridge that caused the warning. Make sure there is no nozzle clogging.
NO CARTRIDGE	No ink cartridge in the slot.	<ul style="list-style-type: none"> Insert a cartridge in the slot that caused the warning. Make sure that the cartridge is inserted correctly. Temporarily turn off the main power supply, and then turn it on again. If the message appears again, contact your dealer, or our sales office or call center.
INK END	The ink cartridge is out of ink.	<ul style="list-style-type: none"> Replace the cartridge that caused the warning.
Ink Near End	The ink cartridge is almost out of ink.	<ul style="list-style-type: none"> Be aware that ink will run out soon.
Expiration	The ink has expired.	<ul style="list-style-type: none"> Replace with new ink or use up as quickly as possible. Printing is possible.
Expiration1MONTH	One month has passed since the ink expiration date.	<ul style="list-style-type: none"> Replace with new ink or use up as quickly as possible. Printing is possible.
Expiration2MONTH	Two months have passed since the ink expiration date.	<ul style="list-style-type: none"> Replace with new ink. Printing is not possible.

Error messages

Respond to error messages as follows.

If the message is displayed again despite the measures you have taken, contact your dealer, or our sales office or call center.

Message	Cause	Corrective action
ERROR 122 CHECK:SDRAM	An SDRAM error occurred.	<ul style="list-style-type: none"> Temporarily turn off the main power supply, and then turn it on again. If the message appears again, contact your dealer, or our sales office or call center.
ERROR 128 HDC FIFO OVER	A head control PCB error occurred.	
ERROR 128 HDC FIFO UNDER		
ERROR 129 BATTERY EXCHANGE	The machine has detected that the internal clock battery is depleted.	<ul style="list-style-type: none"> Contact your dealer, or our sales office or call center.
ERROR 130 HD DATA SEQ	Head data transfer error.	<ul style="list-style-type: none"> Temporarily turn off the main power supply, and then turn it on again. If the message appears again, contact your dealer, or our sales office or call center.
ERROR 146 E-LOG SEQ	Event log sequential number error.	
ERROR 151 Main PCB V1R2	An error occurred in the power supply system of the main PCB.	
ERROR 152 Main PCB V2R5		
ERROR 153 Main PCB V3R3		
ERROR 154 Main PCB V05		
ERROR 157 Main PCB VTT		
ERROR 16e Main PCB V3R3B		
ERROR 15f HEAD DRIVE HOT		
ERROR 171 NEW HEAD CONNECT		
ERROR 186 HDC OVERFLOW	Printing waveform error detected.	
ERROR 186 HDC UNDERFLOW		
ERROR 187 HDC SLEW RATE		
ERROR 188 HDC MEMORY		

Message	Cause	Corrective action	
ERROR 18a Main PCB V_CORE	An error occurred in the main PCB power supply.	<ul style="list-style-type: none"> Temporarily turn off the main power supply, and then turn it on again. If the message appears again, contact your dealer, or our sales office or call center. 	
ERROR 18c Main PCB V12			
ERROR 190 Main PCB V42-1			
ERROR 192 COMIO PCB V1R2	An error occurred in the COM16 PCB power supply.		
ERROR 193 COMIO PCB V2R5			
ERROR 194 COMIO PCB V3R3			
ERROR 195 COMIO PCB V24			
ERROR 1a0 SLDR2H PCB V1R2	An error occurred in the slider E PCB power supply.		
ERROR 1a6 SLDR2H PCB V2R5			
ERROR 1a7 SLDR2H PCB V3R3			
ERROR 1a8 SLDR2H PCB V5			
ERROR 1a9 SLDR2H PCB V42			
ERROR 201 COMMAND ERROR	The machine received data other than print data. Otherwise, an error occurred with the transmitted print data.	<ul style="list-style-type: none"> Securely connect the interface cable. Use an interface cable conforming to the specifications. 	
ERROR 202 PARAMETER ERROR	An error occurred with the transmitted print data.		
ERROR 304 USB INIT ERR	An error occurred with USB communication.	<ul style="list-style-type: none"> Temporarily turn off the main power supply, and then turn it on again. If the message appears again, contact your dealer, or our sales office or call center. 	
ERROR 305 USB TIME OUT			
ERROR 401 MOTOR X	The X motor was overloaded.		
ERROR 402 MOTOR Y	The Y motor was overloaded.		
ERROR 403 X Current	An overcurrent error was detected in the X motor.		
ERROR 404 Y Current	An overcurrent error was detected in the Y motor.		
ERROR 505 MEDIA JAM	Media has jammed.		<ul style="list-style-type: none"> Remove and reload the media.

Message	Cause	Corrective action
ERROR 509 HDC POSCNT	A position control error occurred.	<ul style="list-style-type: none"> Temporarily turn off the main power supply, and then turn it on again. If the message appears again, contact your dealer, or our sales office or call center.
ERROR 50a Y ORIGIN	Y-origin could not be detected.	
ERROR 50f L-SCALE BLACK	Linear scale error.	
ERROR 529 LEnc.Count HPC[]		
ERROR 52a LEnc.Count HDC[]		
ERROR 50c MEDIA WIDTH SENSOR	The media width could not be read correctly.	<ul style="list-style-type: none"> Check the media loading position (🔧 P.2-6). Clean the media sensors (🔧 P.4-10). Temporarily turn off the main power supply, and then turn it on again.
ERROR 516 MEDIA SET POSITION R	The media was loaded outside the range of valid positions.	<ul style="list-style-type: none"> Check the media loading position (🔧 P.2-6).
ERROR 528 PUMP MOTOR SENSOR	Pump sensor detection error	<ul style="list-style-type: none"> Temporarily turn off the main power supply, and then turn it on again. If the message appears again, contact your dealer, or our sales office or call center.
ERROR 602 CARTRIDGE END	Ink end (cannot be used for printing, only when cleaning with the 4-color ink set)	<ul style="list-style-type: none"> Replace with new ink.
ERROR 608 WRONG INK IC	The ink IC chip of the ink cartridge cannot be read correctly.	<ul style="list-style-type: none"> Make sure that the cartridge is inserted correctly. Reinsert the cartridge. Temporarily turn off the main power supply, and then turn it on again. If the message appears again, contact your dealer, or our sales office or call center.
ERROR 612 INK LEVEL LOW	Remaining cartridge volume is less than 60 ml when using 600 ml cartridges.	<ul style="list-style-type: none"> Enter the cartridge weight.
ERROR 613 INK LVL END	Remaining cartridge volume is less than 25 ml when using 600 ml cartridges.	
ERROR 614 Preservation Failure	Failed to write to the ink IC chip during weight input when using 600 ml cartridges.	<ul style="list-style-type: none"> Make sure that the cartridge is inserted correctly. Reinsert the cartridge. Temporarily turn off the main power supply, and then turn it on again. If the message appears again, contact your dealer, or our sales office or call center.
ERROR 627 RE-INSERT CARTRIDGE	A certain amount of time has passed since a cartridge was removed from a slot.	<ul style="list-style-type: none"> Load cartridges.
ERROR 628 WRONG CARTRIDGE	An error occurred with the ink IC chip information for the ink cartridge. Amount used exceeds the stipulated value.	<ul style="list-style-type: none"> Make sure there is no nozzle clogging.
ERROR 702 THERMISTOR CONNECT	Thermistor connection error.	<ul style="list-style-type: none"> Temporarily turn off the main power supply, and then turn it on again. If the message appears again, contact your dealer, or our sales office or call center.
ERROR 710 HEATER TEMP ERROR	Heater temperature error detected. If the temperature issue is not resolved after this error occurs, the machine is forced to shut down.	
ERROR 901 INVALID OPERATION	An error has prevented the function from being performed.	<ul style="list-style-type: none"> Return to the local screen, check the error status, and respond appropriately.

Message	Cause	Corrective action
ERROR 902 DATA REMAIN	There is remaining print data.	<ul style="list-style-type: none"> Clear the data (☞ P.2-14).
ERROR 90d NO HEAD SELECT	An error occurred in the mounted heads.	<ul style="list-style-type: none"> Temporarily turn off the main power supply, and then turn it on again. If the message appears again, contact your dealer, or our sales office or call center.
ERROR 90f PRINT AREA SHORT	The media is not wide or long enough for printing.	<ul style="list-style-type: none"> Switch to media that is wide or long enough. If media width has narrowed because you have moved the origin, move the origin to the right to widen the effective media width.
ERROR 04 PARAM ROM	An error occurred with the main PCB FROM.	<ul style="list-style-type: none"> Temporarily turn off the main power supply, and then turn it on again. If the message appears again, contact your dealer, or our sales office or call center.

SYSTEM HALT

Message	Corrective action
SYSTEM HALT (*) 000: MESSAGE	<ul style="list-style-type: none"> Temporarily turn off the main power supply, and then turn it on again. If the message appears again, check the number and contact your dealer, or our sales office or call center. ("000" represents the error number.)
SYSTEM HALT (*) 406 : WIPER ORG	<ul style="list-style-type: none"> Perform cleaning around the wiper. Temporarily turn off the main power supply, and then turn it on again. If the message appears again, check the number and contact your dealer, or our sales office or call center.

Chapter 6 Appendix



About this chapter

This chapter lists the specifications and functions of the machine.

Specifications	6-2
Main unit specifications	6-2
Ink specifications	6-4
Order for Loading Ink Cartridges	6-5
LICENSE Library	6-6

Specifications

Main unit specifications

Item		TxF150-75	TxF300-75	Remarks
Head		On-demand piezo head (1 head, 8 nozzles; 180 nozzles per line; pitch between nozzles: 180 dpi)		
Print resolution		x-dpi: 720/1440 y-dpi: 720		Variable dot is supported
Ink		CMYK + W		IC chip-equipped TxF150-75: 6 Cartridge TxF300-75: 8 Cartridge
Ink supply		Ink end: weight entry + internal count		
Ink capacity		1 each of 600ml cartridge CMYK, 2 each of 500ml cartridge W	1 each of 600ml cartridge CMYK, 4 each of 500ml cartridge W	
Compatible media		Film		
Maximum printing width		800mm		At minimum horizontal dead space
Media specifications	Maximum width	810mm		
	Minimum width	210mm		
	Thickness	Max. 1.0 mm		
	Roll outside diameter	Max. 250 mm		
	Roll weight	Max. 45 kg No feed failures due to sagging caused by weight when the roll is retained at both ends		
	Roll inside diameter	2 inches or 3 inches		
	Print side	Inside/outside (not required)		
	Take-up treatment	Taped or loosely affixed to paper core		
Margin	Roll	Left and right: 15 mm (default)Front: 120 mmRear: 150 mm		Tolerance excluding media skewing: 2 mm Left/right margins: changeable Min. 5 mm
	Leaf	Left and right: 15 mm (default)Front: 120 mmRear: 150 mm		
Origin alignment (LED pointer)		Alignment with the LED pointer mounted on the head actuator Use pointer to change the plotting origin to a value that exceeds the initial value.		Excluding media size variation Excluding initial loading fluctuations
Distance accuracy	Absolute accuracy	± 0.3 or $\pm 0.3\%$ of specified distance, whichever is larger		
	Reproducibility	± 0.2 or $\pm 0.1\%$ of specified distance, whichever is larger		
Perpendicularity		$\pm 0.5/1,000$		
Media skew		5 or less / 10 m		
Printing gap		Manual, three settings (2.0, 2.5, 3.0)		
Media heater		PRE/PRINT/AFTER: 50/50/50 Independent control of the three systems		
Ink sediment cycle		Provided for W		
Cleaning cartridge		Provided		
Nozzle Missing Detector (NCU)		Provided		
Media cutting		Standard Cutting precision (steps): 0.5 mm or lower		
Waste Ink Tank		Bottle type (2000 ml)		
Image memory		256MB SD-RAM		
Interface	Standard	1) USB 2.0 2)Ethernet ; 1000BASE-T		
Command		MRL- IV		
MAPS		MAPS4		

Item		TxF150-75	TxF300-75	Remarks
Noise levels	During standby	45 dB or lower (FAST-A, 1 m on all sides)		
	During continuous printing	60 dB or lower		
	During discontinuous printing	70 dB or lower		
Compliance with standards		1) VCCI class A 2) FCC class A 3) IEC 62368-1 ETL compliance 4) CE marking (EMC Directive, Low Voltage Directive, Machinery Directive, RoHS Directive) 5) CB Report 6) REACH and Energy Star 7) RCM 8) KC		
Power supply		(100 to 120 V/ AC200 to 240 V AC) 50/60Hz ±1Hz		Manual input switching Remote switching function available Sleep function available
		Inlet1: control + heater		
Power consumption	Maximum	Not exceeding AC100-120V : 900W, AC200-240V : 1200W	Not exceeding AC100-120V : 1000W, AC200-240V : 1300W	Including the main unit and heater Excluding options
	Minimum	Not exceeding AC100-120V : 5.9W, AC200-240V : 5.9W (Sleep mode)		
Installation environment	Operating temp.	20–30°C		In an environment outside the range shown on the left, the ink ejection stability may deteriorate.
	Relative humidity	35–65% RH (no condensation)		
	Temp. range for guaranteed accuracy	20–25°C (68–77°F)		
	Temp. gradient	±10°C/h or less (±50°F/h or less)		
	Dust	0.15 mg/m ³ (typical office)		
	Maximum operating altitude	2,000m		
Weight		Main unit: 126 kg Packing; 180kg		
Dimensions (W x D x H)		1,965 mm × 700 mm × 1,392 mm		

Ink specifications

Item		Thermal transfer pigment ink
Supply		Dedicated ink cartridges
Color		Cyan Magenta Yellow Black White
Ink capacity		Color: 600 ml, White: 500 ml
Expiration date		The expiration date is printed on the ink cartridge. However, after opening, within one month even it is within the expiration date.
Storage temperature	When stored	10–35°C / 50–95°F (ave. daily temp.) • Keep the container completely shut when storing. • Stored in a dry, cool, dark, and well-ventilated place.
	During transportation	0–40°C (32–104°F) • Avoid places outside of this range.



- Do not disassemble or refill ink cartridges.
- Ink may freeze if kept in a cold place for an extended period.
- Ink that has frozen is no longer usable. Store ink where there is no risk of freezing.

Order for Loading Ink Cartridges



- Load ink cartridges according to the cartridge label colors under the ink station.

[TxF150-75]

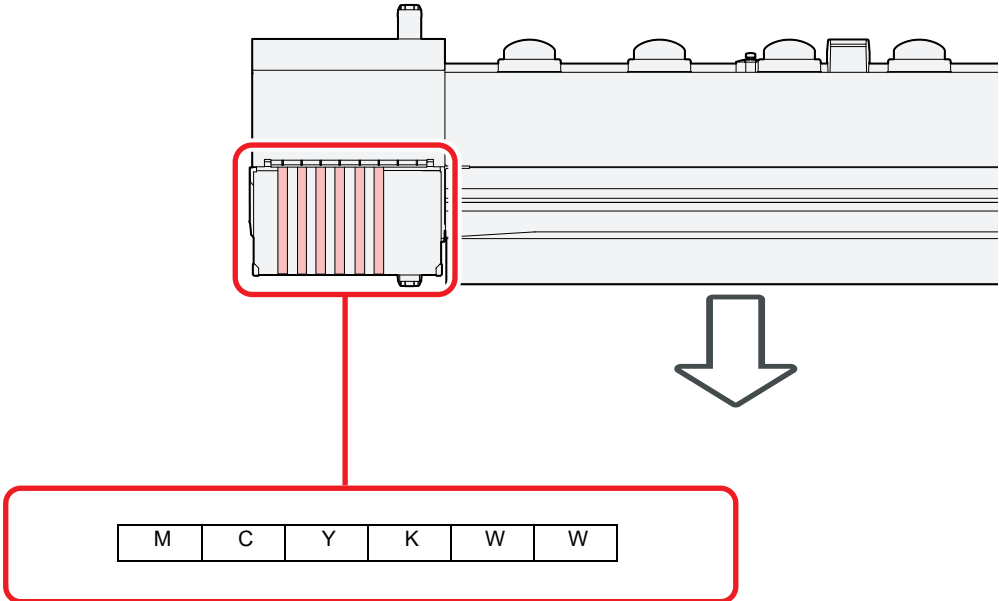

[TxF300-75]

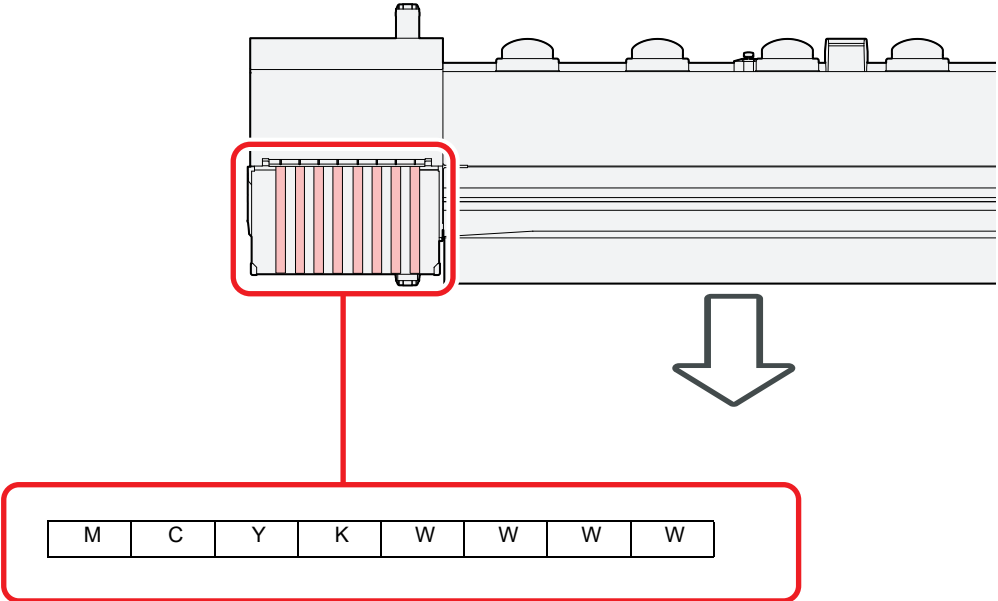

LICENSE Library

Mimaki printer firmware

Copyright ©2020 MIMAKI ENGINEERING CO.,LTD. All rights reserved.

This product contain open source software listed in the tables below.

Component	License
StarterWare for ARM® based TI Sitara Processors	BSD-TI

The following license terms and conditions shall apply to the open source software listed in the table above:

BSD-TI

Copyright (C) 2010 Texas Instruments Incorporated - <http://www.ti.com/>

Redistribution and use in source and binary forms, with or without modification, are permitted provided that the following conditions are met:

1. Redistributions of source code must retain the above copyright notice, this list of conditions and the following disclaimer.
2. Redistributions in binary form must reproduce the above copyright notice, this list of conditions and the following disclaimer in the documentation and/or other materials provided with the distribution.
3. Neither the name of Texas Instruments Incorporated nor the names of its contributors may be used to endorse or promote products derived from this software without specific prior written permission.

THIS SOFTWARE IS PROVIDED BY THE COPYRIGHT HOLDERS AND CONTRIBUTORS "AS IS" AND ANY EXPRESS OR IMPLIED WARRANTIES, INCLUDING, BUT NOT LIMITED TO, THE IMPLIED WARRANTIES OF MERCHANTABILITY AND FITNESS FOR A PARTICULAR PURPOSE ARE DISCLAIMED. IN NO EVENT SHALL THE COPYRIGHT OWNER OR CONTRIBUTORS BE LIABLE FOR ANY DIRECT, INDIRECT, INCIDENTAL, SPECIAL, EXEMPLARY, OR CONSEQUENTIAL DAMAGES (INCLUDING, BUT NOT LIMITED TO, PROCUREMENT OF SUBSTITUTE GOODS OR SERVICES; LOSS OF USE, DATA, OR PROFITS; OR BUSINESS INTERRUPTION) HOWEVER CAUSED AND ON ANY THEORY OF LIABILITY, WHETHER IN CONTRACT, STRICT LIABILITY, OR TORT (INCLUDING NEGLIGENCE OR OTHERWISE) ARISING IN ANY WAY OUT OF THE USE OF THIS SOFTWARE, EVEN IF ADVISED OF THE POSSIBILITY OF SUCH DAMAGE.

Index

A

Adjusting head height	2-6
Adjustment lever and range	2-6
Auto cleaning setup	3-6
Auto Maintenance Functions	4-14
Cleaning interval	4-14
Pump tube/nozzle washing	4-14
Setting the refresh interval	4-14
Type of cleaning	4-14

C

Caution	0-v
Changing heater temperature settings	2-10
Changing the printing origin	2-9
Cleaning and replacing pinch rollers	4-17
Cleaning head nozzles	4-8
Cleaning media holders	4-10
Connecting Cables	1-9
Correcting media-feeding during printing	2-12
Correction pattern	3-3
Cutting media	2-14

D

Data Clear	2-14
Displaying information	3-19
Drying time setup	3-5

E

Enabling event mail	3-12
END/POWER key	2-5
Entering the remaining amount of media	2-9
ERROR HISTORY	3-19
Error messages	5-6
Errors when performing operations	5-4

F

FCC statement (USA)	0-v
Feed Correction Settings	2-12, 3-3
Feed speed setup	3-5

G

Guidelines for setting the origin position	2-9
--	-----

H

Head Cleaning	2-11
About head cleaning	2-11
Performing head cleaning based on test printing	

results	2-11
Heater setup	3-4

I

If the Positions of Dots Shift	2-13, 3-3
Information Menu	3-19
Information menu table	3-19
Initializing settings	3-15
Ink expiration date	1-14
Interference	0-v
Interval wiping setup	3-6

L

LAN cable	1-10
LED pointer	2-9
LIST	3-19
Loading roll media	2-7
Logical seek setup	3-4

M

Machine restrictions	1-14
Machine Setup Menu	3-7
Machine setup menu table	3-7
Main power switch	2-5
Maintenance Precautions	4-2
Margin (left/right) setup	3-5
Menu Mode	1-17
Function mode	1-17
Local mode	1-17
Not-Ready mode	1-17
Remote mode	1-17
Messages to check waste ink	4-19

N

NOZZLE CHECK

Printing operations when nozzle clogging is determined or errors occur	3-17
Nozzle Check	
Setting judgment conditions	3-18
Setting nozzle checking during printing	3-18
Setting auto nozzle recovery	3-18
Nozzle Check Menu	3-16
Nozzle check menu table	3-16
Nozzle recovery function	4-13
Resetting your set values	4-13

P

Part Names and Functions	1-4
Capping station	1-8
Carriage	1-8
Cutter blade and cutting slot	1-8
Front of machine	1-4
Media sensor	1-8

Operating panel	1-6
Pinch rollers and grit rollers	1-9
Rear/side	1-5
Place of installation	0-ix
Power cable	1-10
Precautions on handling ink cartridges	1-11
Preparing the Heater	2-10
Printing Data	2-13
Printing Workflow	2-4

R

Replacing cutter blades	4-18
Replacing the CP pad set	4-17
Replacing the exhaust box filter or exhaust box 4-16	
Replacing the waste ink tank	4-19
Replacing wipers	4-16
Requests	0-v

S

Safety Precautions	0-vi
Installation precautions	0-ix
Precautions and notes	0-viii
Warnings and precautions in use	0-vi
Sending test email	3-13
Setting auto power-off	3-9
Setting events that trigger event mail	3-12
Setting remaining media display	3-9
Setting space feed mode	3-11
Setting the email address	3-12
Setting the event mail function	3-12
Setting the key buzzer	3-10
Setting the language	3-9
Setting the network	3-11
Setting the server	3-12
Setting the subject	3-12
Setting the time	3-9
Setting units (temperature/length)	3-9
Setting view feed	3-10
Setup Menu	3-2
Setup menu table	3-2
Specifications	
Ink specifications	6-4
Machine specifications	6-2
Starting printing	2-13
Stopping printing	2-14
Symbols	0-vi

T

Temperature of working environment	0-ix
Test Printing	2-10
Check before test printing	2-11
Relationship of test patterns to head rows	2-10
Test printing precautions	2-10
Troubleshooting	
Image quality is poor	5-3

Ink cartridge warning appears	5-3
Media is dirty	5-2
Media jams	5-2
Nozzles are clogged	5-3
Power does not turn on	5-2
Printing is not possible	5-2
Turning the power off	2-5
Precautions on turning the power off	2-5
Turning the power on	2-5

U

USAGE	3-19
PRINT AREA	3-19
PRINT LENGTH	3-19
USE TIME	3-19
WASTE TANK	3-19
WIPING	3-19
USB 2.0 interface cable	1-9
USB 2.0 interface precautions	1-9

V

Vacuum fan setup	3-5
VERSION	3-19

W

Warning messages	5-4
Errors when performing operations	5-4
Ink errors	5-5
Messages displayed in local mode	5-4
Warning/Error Messages	5-4
When using cartridges	3-9

TxF150-75/TxF300-75 Operation Manual

March 2024

Issued by Mimaki Engineering Co., Ltd.
Place of issue Mimaki Engineering Co., Ltd.
2182-3 Shigeno-otsu, Tomi-shi, Nagano 389-0512 JAPAN

D203671-21-01032024

